

PIC16F84A
Data Sheet

18-pin Enhanced FLASH/EEPROM
8-bit Microcontroller

Note the following details of the code protection feature on PICmicro® MCUs.

- The PICmicro family meets the specifications contained in the Microchip Data Sheet.
- Microchip believes that its family of PICmicro microcontrollers is one of the most secure products of its kind on the market today, when used in the intended manner and under normal conditions.
- There are dishonest and possibly illegal methods used to breach the code protection feature. All of these methods, to our knowledge, require using the PICmicro microcontroller in a manner outside the operating specifications contained in the data sheet. The person doing so may be engaged in theft of intellectual property.
- Microchip is willing to work with the customer who is concerned about the integrity of their code.
- Neither Microchip nor any other semiconductor manufacturer can guarantee the security of their code. Code protection does not mean that we are guaranteeing the product as “unbreakable”.
- Code protection is constantly evolving. We at Microchip are committed to continuously improving the code protection features of our product.

If you have any further questions about this matter, please contact the local sales office nearest to you.

Information contained in this publication regarding device applications and the like is intended through suggestion only and may be superseded by updates. It is your responsibility to ensure that your application meets with your specifications. No representation or warranty is given and no liability is assumed by Microchip Technology Incorporated with respect to the accuracy or use of such information, or infringement of patents or other intellectual property rights arising from such use or otherwise. Use of Microchip's products as critical components in life support systems is not authorized except with express written approval by Microchip. No licenses are conveyed, implicitly or otherwise, under any intellectual property rights.

Trademarks

The Microchip name and logo, the Microchip logo, PIC, PICmicro, PICMASTER, PICSTART, PRO MATE, KEELOQ, SEEVAL, MPLAB and The Embedded Control Solutions Company are registered trademarks of Microchip Technology Incorporated in the U.S.A. and other countries.

Total Endurance, ICSP, In-Circuit Serial Programming, Filter-Lab, MXDEV, microID, *FlexROM*, *fuzzyLAB*, MPASM, MPLINK, MPLIB, PICC, PICDEM, PICDEM.net, ICEPIC, Migratable Memory, FanSense, ECONOMONITOR, Select Mode and microPort are trademarks of Microchip Technology Incorporated in the U.S.A.

Serialized Quick Term Programming (SQTP) is a service mark of Microchip Technology Incorporated in the U.S.A.

All other trademarks mentioned herein are property of their respective companies.

© 2001, Microchip Technology Incorporated, Printed in the U.S.A., All Rights Reserved.

 Printed on recycled paper.

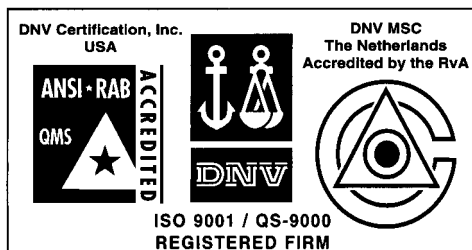

Microchip received QS-9000 quality system certification for its worldwide headquarters, design and wafer fabrication facilities in Chandler and Tempe, Arizona in July 1999. The Company's quality system processes and procedures are QS-9000 compliant for its PICmicro® 8-bit MCUs, KEELOQ® code hopping devices, Serial EEPROMs and microperipheral products. In addition, Microchip's quality system for the design and manufacture of development systems is ISO 9001 certified.

18-pin *Enhanced* FLASH/EEPROM 8-Bit Microcontroller

High Performance RISC CPU Features:

- Only 35 single word instructions to learn
- All instructions single-cycle except for program branches which are two-cycle
- Operating speed: DC - 20 MHz clock input
DC - 200 ns instruction cycle
- 1024 words of program memory
- 68 bytes of Data RAM
- 64 bytes of Data EEPROM
- 14-bit wide instruction words
- 8-bit wide data bytes
- 15 Special Function Hardware registers
- Eight-level deep hardware stack
- Direct, indirect and relative addressing modes
- Four interrupt sources:
 - External RB0/INT pin
 - TMR0 timer overflow
 - PORTB<7:4> interrupt-on-change
 - Data EEPROM write complete

Peripheral Features:

- 13 I/O pins with individual direction control
- High current sink/source for direct LED drive
 - 25 mA sink max. per pin
 - 25 mA source max. per pin
- TMR0: 8-bit timer/counter with 8-bit programmable prescaler

Special Microcontroller Features:

- 10,000 erase/write cycles *Enhanced* FLASH Program memory typical
- 10,000,000 typical erase/write cycles EEPROM Data memory typical
- EEPROM Data Retention > 40 years
- In-Circuit Serial Programming™ (ICSP™) - via two pins
- Power-on Reset (POR), Power-up Timer (PWRT), Oscillator Start-up Timer (OST)
- Watchdog Timer (WDT) with its own On-Chip RC Oscillator for reliable operation
- Code protection
- Power saving SLEEP mode
- Selectable oscillator options

Pin Diagrams

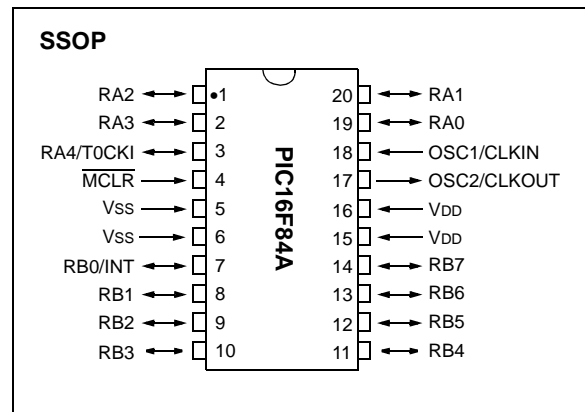
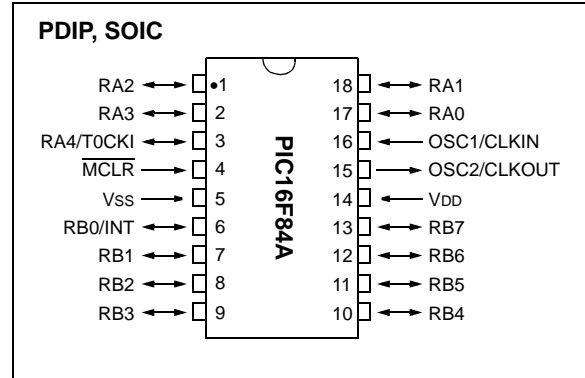

CMOS Enhanced FLASH/EEPROM Technology:

- Low power, high speed technology
- Fully static design
- Wide operating voltage range:
 - Commercial: 2.0V to 5.5V
 - Industrial: 2.0V to 5.5V
- Low power consumption:
 - < 2 mA typical @ 5V, 4 MHz
 - 15 µA typical @ 2V, 32 kHz
 - < 0.5 µA typical standby current @ 2V

PIC16F84A

Table of Contents

1.0	Device Overview	3
2.0	Memory Organization	5
3.0	Data EEPROM Memory	13
4.0	I/O Ports	15
5.0	Timer0 Module	19
6.0	Special Features of the CPU	21
7.0	Instruction Set Summary	35
8.0	Development Support	43
9.0	Electrical Characteristics	49
10.0	DC/AC Characteristic Graphs	61
11.0	Packaging Information	71
	Appendix A: Revision History	75
	Appendix B: Conversion Considerations	76
	Appendix C: Migration from Baseline to Mid-Range Devices	78
	Index	79
	On-Line Support	83
	Reader Response	84
	PIC16F84A Product Identification System	85

TO OUR VALUED CUSTOMERS

It is our intention to provide our valued customers with the best documentation possible to ensure successful use of your Microchip products. To this end, we will continue to improve our publications to better suit your needs. Our publications will be refined and enhanced as new volumes and updates are introduced.

If you have any questions or comments regarding this publication, please contact the Marketing Communications Department via E-mail at docerrors@mail.microchip.com or fax the **Reader Response Form** in the back of this data sheet to (480) 792-4150. We welcome your feedback.

Most Current Data Sheet

To obtain the most up-to-date version of this data sheet, please register at our Worldwide Web site at:

<http://www.microchip.com>

You can determine the version of a data sheet by examining its literature number found on the bottom outside corner of any page. The last character of the literature number is the version number, (e.g., DS30000A is version A of document DS30000).

Errata

An errata sheet, describing minor operational differences from the data sheet and recommended workarounds, may exist for current devices. As device/documentation issues become known to us, we will publish an errata sheet. The errata will specify the revision of silicon and revision of document to which it applies.

To determine if an errata sheet exists for a particular device, please check with one of the following:

- Microchip's Worldwide Web site; <http://www.microchip.com>
- Your local Microchip sales office (see last page)
- The Microchip Corporate Literature Center; U.S. FAX: (480) 792-7277

When contacting a sales office or the literature center, please specify which device, revision of silicon and data sheet (include literature number) you are using.

Customer Notification System

Register on our web site at www.microchip.com/cn to receive the most current information on all of our products.

1.0 DEVICE OVERVIEW

This document contains device specific information for the operation of the PIC16F84A device. Additional information may be found in the PICmicro™ Mid-Range Reference Manual, (DS33023), which may be downloaded from the Microchip website. The Reference Manual should be considered a complementary document to this data sheet, and is highly recommended reading for a better understanding of the device architecture and operation of the peripheral modules.

The PIC16F84A belongs to the mid-range family of the PICmicro® microcontroller devices. A block diagram of the device is shown in Figure 1-1.

The program memory contains 1K words, which translates to 1024 instructions, since each 14-bit program memory word is the same width as each device instruction. The data memory (RAM) contains 68 bytes. Data EEPROM is 64 bytes.

There are also 13 I/O pins that are user-configured on a pin-to-pin basis. Some pins are multiplexed with other device functions. These functions include:

- External interrupt
- Change on PORTB interrupt
- Timer0 clock input

Table 1-1 details the pinout of the device with descriptions and details for each pin.

FIGURE 1-1: PIC16F84A BLOCK DIAGRAM

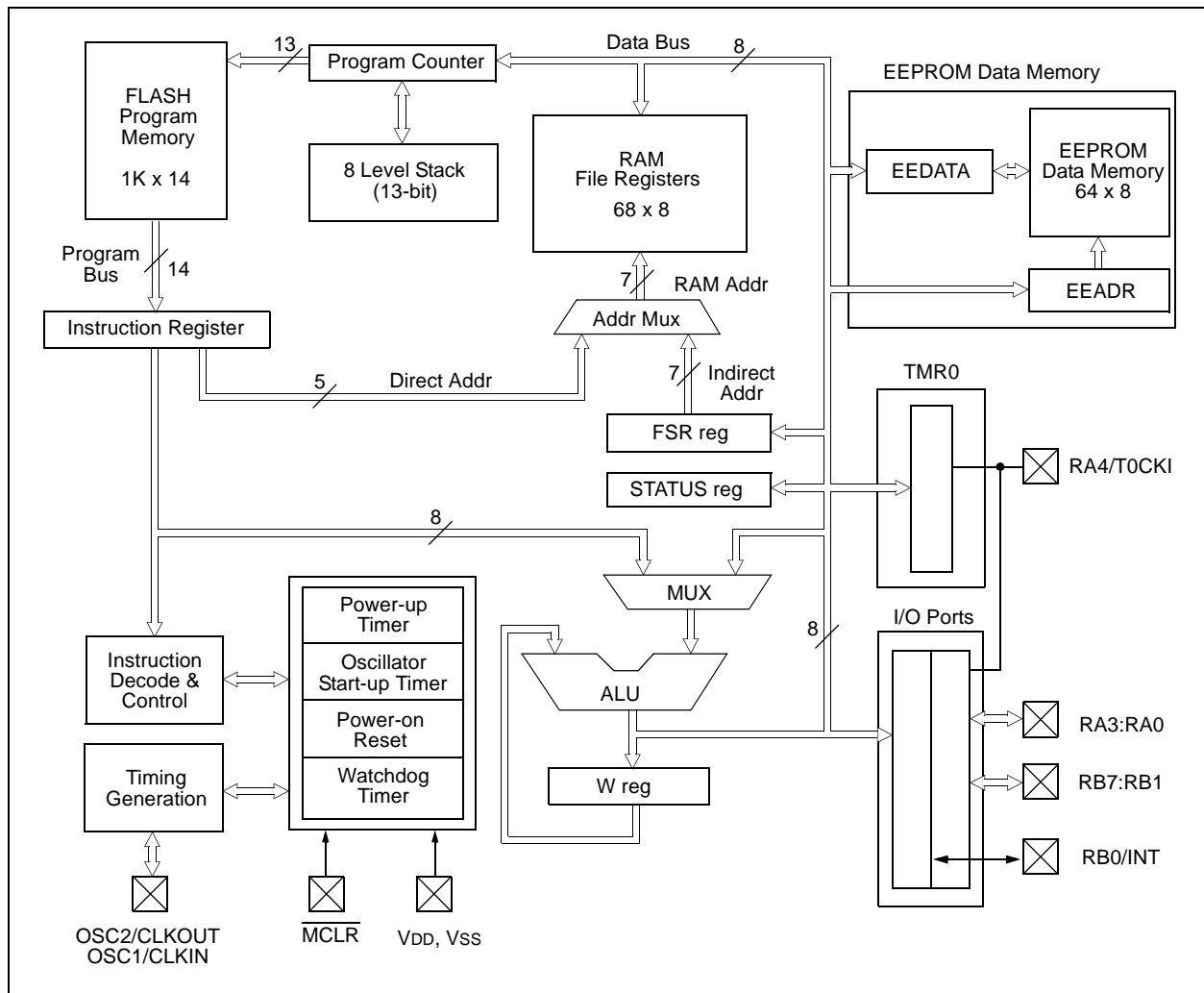

PIC16F84A

TABLE 1-1: PIC16F84A PINOUT DESCRIPTION

Pin Name	PDIP No.	SOIC No.	SSOP No.	I/O/P Type	Buffer Type	Description
OSC1/CLKIN	16	16	18	I	ST/CMOS ⁽³⁾	Oscillator crystal input/external clock source input.
OSC2/CLKOUT	15	15	19	O	—	Oscillator crystal output. Connects to crystal or resonator in Crystal Oscillator mode. In RC mode, OSC2 pin outputs CLKOUT, which has 1/4 the frequency of OSC1 and denotes the instruction cycle rate.
MCLR	4	4	4	I/P	ST	Master Clear (Reset) input/programming voltage input. This pin is an active low RESET to the device.
RA0	17	17	19	I/O	TTL	PORTA is a bi-directional I/O port. Can also be selected to be the clock input to the TMR0 timer/counter. Output is open drain type.
RA1	18	18	20	I/O	TTL	
RA2	1	1	1	I/O	TTL	
RA3	2	2	2	I/O	TTL	
RA4/T0CKI	3	3	3	I/O	ST	
RB0/INT	6	6	7	I/O	TTL/ST ⁽¹⁾	PORTB is a bi-directional I/O port. PORTB can be software programmed for internal weak pull-up on all inputs. RB0/INT can also be selected as an external interrupt pin. Interrupt-on-change pin. Interrupt-on-change pin. Interrupt-on-change pin. Serial programming clock. Interrupt-on-change pin. Serial programming data.
RB1	7	7	8	I/O	TTL	
RB2	8	8	9	I/O	TTL	
RB3	9	9	10	I/O	TTL	
RB4	10	10	11	I/O	TTL	
RB5	11	11	12	I/O	TTL	
RB6	12	12	13	I/O	TTL/ST ⁽²⁾	
RB7	13	13	14	I/O	TTL/ST ⁽²⁾	
VSS	5	5	5,6	P	—	Ground reference for logic and I/O pins.
VDD	14	14	15,16	P	—	Positive supply for logic and I/O pins.

Legend: I = input O = Output I/O = Input/Output P = Power
 — = Not used TTL = TTL input ST = Schmitt Trigger input

- Note 1:** This buffer is a Schmitt Trigger input when configured as the external interrupt.
Note 2: This buffer is a Schmitt Trigger input when used in Serial Programming mode.
Note 3: This buffer is a Schmitt Trigger input when configured in RC oscillator mode and a CMOS input otherwise.

2.0 MEMORY ORGANIZATION

There are two memory blocks in the PIC16F84A. These are the program memory and the data memory. Each block has its own bus, so that access to each block can occur during the same oscillator cycle.

The data memory can further be broken down into the general purpose RAM and the Special Function Registers (SFRs). The operation of the SFRs that control the “core” are described here. The SFRs used to control the peripheral modules are described in the section discussing each individual peripheral module.

The data memory area also contains the data EEPROM memory. This memory is not directly mapped into the data memory, but is indirectly mapped. That is, an indirect address pointer specifies the address of the data EEPROM memory to read/write. The 64 bytes of data EEPROM memory have the address range 0h-3Fh. More details on the EEPROM memory can be found in Section 3.0.

Additional information on device memory may be found in the PICmicro™ Mid-Range Reference Manual, (DS33023).

2.1 Program Memory Organization

The PIC16FXX has a 13-bit program counter capable of addressing an 8K x 14 program memory space. For the PIC16F84A, the first 1K x 14 (0000h-03FFh) are physically implemented (Figure 2-1). Accessing a location above the physically implemented address will cause a wraparound. For example, for locations 20h, 420h, 820h, C20h, 1020h, 1420h, 1820h, and 1C20h, the instruction will be the same.

The RESET vector is at 0000h and the interrupt vector is at 0004h.

FIGURE 2-1: PROGRAM MEMORY MAP AND STACK - PIC16F84A

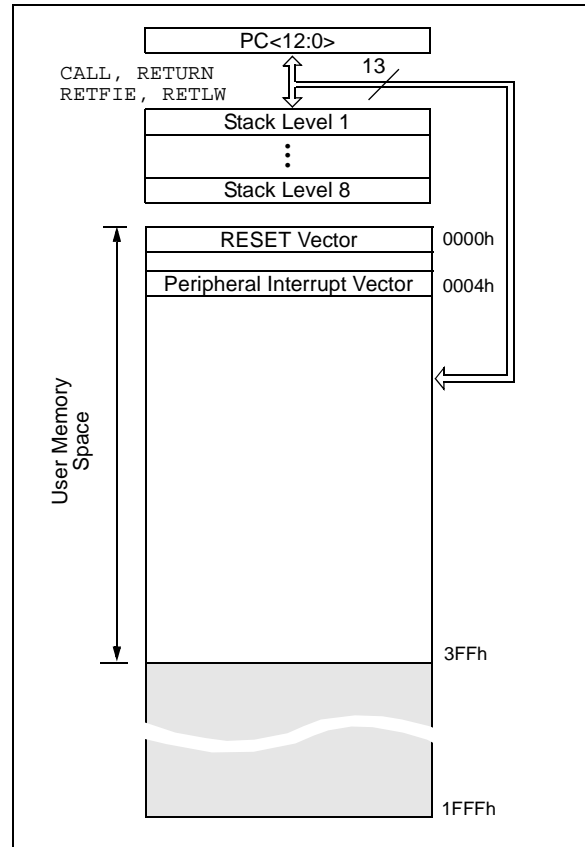

PIC16F84A

2.2 Data Memory Organization

The data memory is partitioned into two areas. The first is the Special Function Registers (SFR) area, while the second is the General Purpose Registers (GPR) area. The SFRs control the operation of the device.

Portions of data memory are banked. This is for both the SFR area and the GPR area. The GPR area is banked to allow greater than 116 bytes of general purpose RAM. The banked areas of the SFR are for the registers that control the peripheral functions. Banking requires the use of control bits for bank selection. These control bits are located in the STATUS Register. Figure 2-2 shows the data memory map organization.

Instructions *MOVWF* and *MOVF* can move values from the W register to any location in the register file ("F"), and vice-versa.

The entire data memory can be accessed either directly using the absolute address of each register file or indirectly through the File Select Register (FSR) (Section 2.5). Indirect addressing uses the present value of the RP0 bit for access into the banked areas of data memory.

Data memory is partitioned into two banks which contain the general purpose registers and the special function registers. Bank 0 is selected by clearing the RP0 bit (STATUS<5>). Setting the RP0 bit selects Bank 1. Each Bank extends up to 7Fh (128 bytes). The first twelve locations of each Bank are reserved for the Special Function Registers. The remainder are General Purpose Registers, implemented as static RAM.

2.2.1 GENERAL PURPOSE REGISTER FILE

Each General Purpose Register (GPR) is 8-bits wide and is accessed either directly or indirectly through the FSR (Section 2.5).

The GPR addresses in Bank 1 are mapped to addresses in Bank 0. As an example, addressing location 0Ch or 8Ch will access the same GPR.

FIGURE 2-2: REGISTER FILE MAP - PIC16F84A

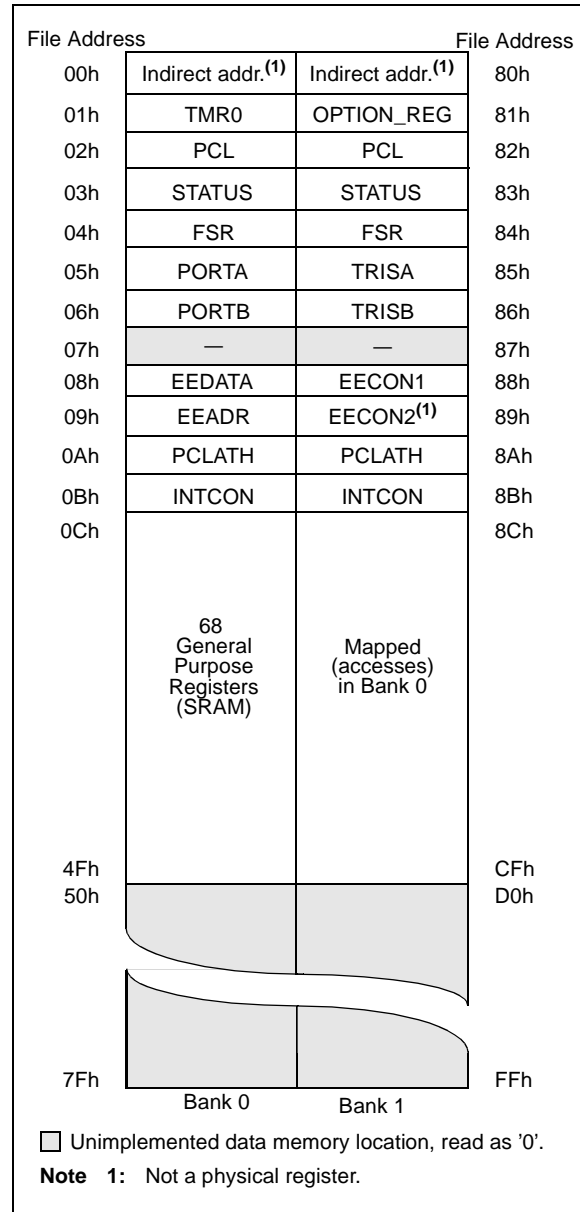

2.3 Special Function Registers

The Special Function Registers (Figure 2-2 and Table 2-1) are used by the CPU and Peripheral functions to control the device operation. These registers are static RAM.

The special function registers can be classified into two sets, core and peripheral. Those associated with the core functions are described in this section. Those related to the operation of the peripheral features are described in the section for that specific feature.

TABLE 2-1: SPECIAL FUNCTION REGISTER FILE SUMMARY

Addr	Name	Bit 7	Bit 6	Bit 5	Bit 4	Bit 3	Bit 2	Bit 1	Bit 0	Value on Power-on RESET	Details on page	
Bank 0												
00h	INDF	Uses contents of FSR to address Data Memory (not a physical register)								----	----	11
01h	TMR0	8-bit Real-Time Clock/Counter								xxxx	xxxx	20
02h	PCL	Low Order 8 bits of the Program Counter (PC)								0000	0000	11
03h	STATUS ⁽²⁾	IRP	RP1	RP0	\overline{TO}	\overline{PD}	Z	DC	C	0001	1xxx	8
04h	FSR	Indirect Data Memory Address Pointer 0								xxxx	xxxx	11
05h	PORTA ⁽⁴⁾	—	—	—	RA4/T0CKI	RA3	RA2	RA1	RA0	---x	xxxx	16
06h	PORTB ⁽⁵⁾	RB7	RB6	RB5	RB4	RB3	RB2	RB1	RB0/INT	xxxx	xxxx	18
07h	—	Unimplemented location, read as '0'								—	—	—
08h	EEDATA	EEPROM Data Register								xxxx	xxxx	13,14
09h	EEADR	EEPROM Address Register								xxxx	xxxx	13,14
0Ah	PCLATH	—	—	—	Write Buffer for upper 5 bits of the PC ⁽¹⁾				---	0000	11	
0Bh	INTCON	GIE	EEIE	TOIE	INTE	RBIE	TOIF	INTF	RBIF	0000	000x	10
Bank 1												
80h	INDF	Uses Contents of FSR to address Data Memory (not a physical register)								----	----	11
81h	OPTION_REG	RBPU	INTEDG	T0CS	T0SE	PSA	PS2	PS1	PS0	1111	1111	9
82h	PCL	Low order 8 bits of Program Counter (PC)								0000	0000	11
83h	STATUS ⁽²⁾	IRP	RP1	RP0	\overline{TO}	\overline{PD}	Z	DC	C	0001	1xxx	8
84h	FSR	Indirect data memory address pointer 0								xxxx	xxxx	11
85h	TRISA	—	—	—	PORTA Data Direction Register				---	1111	16	
86h	TRISB	PORTB Data Direction Register								1111	1111	18
87h	—	Unimplemented location, read as '0'								—	—	—
88h	EECON1	—	—	—	EEIF	WRERR	WREN	WR	RD	---	x000	13
89h	EECON2	EEPROM Control Register 2 (not a physical register)								----	----	14
0Ah	PCLATH	—	—	—	Write buffer for upper 5 bits of the PC ⁽¹⁾				---	0000	11	
0Bh	INTCON	GIE	EEIE	TOIE	INTE	RBIE	TOIF	INTF	RBIF	0000	000x	10

Legend: x = unknown, u = unchanged, — = unimplemented, read as '0', α = value depends on condition

Note 1: The upper byte of the program counter is not directly accessible. PCLATH is a slave register for PC<12:8>. The contents of PCLATH can be transferred to the upper byte of the program counter, but the contents of PC<12:8> are never transferred to PCLATH.

2: The \overline{TO} and \overline{PD} status bits in the STATUS register are not affected by a \overline{MCLR} Reset.

3: Other (non power-up) RESETS include: external RESET through MCLR and the Watchdog Timer Reset.

4: On any device RESET, these pins are configured as inputs.

5: This is the value that will be in the port output latch.

PIC16F84A

2.3.1 STATUS REGISTER

The STATUS register contains the arithmetic status of the ALU, the RESET status and the bank select bit for data memory.

As with any register, the STATUS register can be the destination for any instruction. If the STATUS register is the destination for an instruction that affects the Z, DC or C bits, then the write to these three bits is disabled. These bits are set or cleared according to device logic. Furthermore, the \overline{TO} and \overline{PD} bits are not writable. Therefore, the result of an instruction with the STATUS register as destination may be different than intended.

For example, `CLRF STATUS` will clear the upper three bits and set the Z bit. This leaves the STATUS register as `000u u1uu` (where u = unchanged).

Only the `BCF`, `BSF`, `SWAPF` and `MOVWF` instructions should be used to alter the STATUS register (Table 7-2), because these instructions do not affect any status bit.

Note 1: The IRP and RP1 bits (STATUS<7:6>) are not used by the PIC16F84A and should be programmed as cleared. Use of these bits as general purpose R/W bits is NOT recommended, since this may affect upward compatibility with future products.

2: The C and DC bits operate as a borrow and digit borrow out bit, respectively, in subtraction. See the `SUBLW` and `SUBWF` instructions for examples.

3: When the STATUS register is the destination for an instruction that affects the Z, DC or C bits, then the write to these three bits is disabled. The specified bit(s) will be updated according to device logic

REGISTER 2-1: STATUS REGISTER (ADDRESS 03h, 83h)

R/W-0	R/W-0	R/W-0	R-1	R-1	R/W-x	R/W-x	R/W-x
IRP	RP1	RP0	\overline{TO}	\overline{PD}	Z	DC	C
bit 7					bit 0		

bit 7-6 **Unimplemented:** Maintain as '0'

bit 5 **RP0:** Register Bank Select bits (used for direct addressing)
 01 = Bank 1 (80h - FFh)
 00 = Bank 0 (00h - 7Fh)

bit 4 **\overline{TO} :** Time-out bit
 1 = After power-up, `CLRWDT` instruction, or `SLEEP` instruction
 0 = A WDT time-out occurred

bit 3 **\overline{PD} :** Power-down bit
 1 = After power-up or by the `CLRWDT` instruction
 0 = By execution of the `SLEEP` instruction

bit 2 **Z:** Zero bit
 1 = The result of an arithmetic or logic operation is zero
 0 = The result of an arithmetic or logic operation is not zero

bit 1 **DC:** Digit carry/borrow bit (`ADDWF`, `ADDLW`, `SUBLW`, `SUBWF` instructions) (for borrow, the polarity is reversed)
 1 = A carry-out from the 4th low order bit of the result occurred
 0 = No carry-out from the 4th low order bit of the result

bit 0 **C:** Carry/borrow bit (`ADDWF`, `ADDLW`, `SUBLW`, `SUBWF` instructions) (for borrow, the polarity is reversed)
 1 = A carry-out from the Most Significant bit of the result occurred
 0 = No carry-out from the Most Significant bit of the result occurred

Note: A subtraction is executed by adding the two's complement of the second operand. For rotate (`RRF`, `RLF`) instructions, this bit is loaded with either the high or low order bit of the source register.

Legend:			
R = Readable bit	W = Writable bit	U = Unimplemented bit, read as '0'	
- n = Value at POR	'1' = Bit is set	'0' = Bit is cleared	x = Bit is unknown

2.3.2 OPTION REGISTER

The OPTION register is a readable and writable register which contains various control bits to configure the TMR0/WDT prescaler, the external INT interrupt, TMR0, and the weak pull-ups on PORTB.

Note: When the prescaler is assigned to the WDT (PSA = '1'), TMR0 has a 1:1 prescaler assignment.

REGISTER 2-2: OPTION REGISTER (ADDRESS 81h)

R/W-1	R/W-1	R/W-1	R/W-1	R/W-1	R/W-1	R/W-1	R/W-1
RBPU	INTEDG	T0CS	T0SE	PSA	PS2	PS1	PS0
bit 7							bit 0

- bit 7 **RBPU:** PORTB Pull-up Enable bit
1 = PORTB pull-ups are disabled
0 = PORTB pull-ups are enabled by individual port latch values
- bit 6 **INTEDG:** Interrupt Edge Select bit
1 = Interrupt on rising edge of RB0/INT pin
0 = Interrupt on falling edge of RB0/INT pin
- bit 5 **T0CS:** TMR0 Clock Source Select bit
1 = Transition on RA4/T0CKI pin
0 = Internal instruction cycle clock (CLKOUT)
- bit 4 **T0SE:** TMR0 Source Edge Select bit
1 = Increment on high-to-low transition on RA4/T0CKI pin
0 = Increment on low-to-high transition on RA4/T0CKI pin
- bit 3 **PSA:** Prescaler Assignment bit
1 = Prescaler is assigned to the WDT
0 = Prescaler is assigned to the Timer0 module

bit 2-0 **PS2:PS0:** Prescaler Rate Select bits

Bit Value	TMR0 Rate	WDT Rate
000	1 : 2	1 : 1
001	1 : 4	1 : 2
010	1 : 8	1 : 4
011	1 : 16	1 : 8
100	1 : 32	1 : 16
101	1 : 64	1 : 32
110	1 : 128	1 : 64
111	1 : 256	1 : 128

Legend:

R = Readable bit W = Writable bit U = Unimplemented bit, read as '0'
 - n = Value at POR '1' = Bit is set '0' = Bit is cleared x = Bit is unknown

PIC16F84A

2.3.3 INTCON REGISTER

The INTCON register is a readable and writable register that contains the various enable bits for all interrupt sources.

Note: Interrupt flag bits are set when an interrupt condition occurs, regardless of the state of its corresponding enable bit or the global enable bit, GIE (INTCON<7>).

REGISTER 2-3: INTCON REGISTER (ADDRESS 0Bh, 8Bh)

R/W-0	R/W-0	R/W-0	R/W-0	R/W-0	R/W-0	R/W-0	R/W-x
GIE	EEIE	TOIE	INTE	RBIE	TOIF	INTF	RBIF
bit 7							bit 0

- bit 7 **GIE:** Global Interrupt Enable bit
 1 = Enables all unmasked interrupts
 0 = Disables all interrupts

- bit 6 **EEIE:** EE Write Complete Interrupt Enable bit
 1 = Enables the EE Write Complete interrupts
 0 = Disables the EE Write Complete interrupt

- bit 5 **TOIE:** TMR0 Overflow Interrupt Enable bit
 1 = Enables the TMR0 interrupt
 0 = Disables the TMR0 interrupt

- bit 4 **INTE:** RB0/INT External Interrupt Enable bit
 1 = Enables the RB0/INT external interrupt
 0 = Disables the RB0/INT external interrupt

- bit 3 **RBIE:** RB Port Change Interrupt Enable bit
 1 = Enables the RB port change interrupt
 0 = Disables the RB port change interrupt

- bit 2 **TOIF:** TMR0 Overflow Interrupt Flag bit
 1 = TMR0 register has overflowed (must be cleared in software)
 0 = TMR0 register did not overflow

- bit 1 **INTF:** RB0/INT External Interrupt Flag bit
 1 = The RB0/INT external interrupt occurred (must be cleared in software)
 0 = The RB0/INT external interrupt did not occur

- bit 0 **RBIF:** RB Port Change Interrupt Flag bit
 1 = At least one of the RB7:RB4 pins changed state (must be cleared in software)
 0 = None of the RB7:RB4 pins have changed state

Legend:

R = Readable bit	W = Writable bit	U = Unimplemented bit, read as '0'
- n = Value at POR	'1' = Bit is set	'0' = Bit is cleared x = Bit is unknown

2.4 PCL and PCLATH

The program counter (PC) specifies the address of the instruction to fetch for execution. The PC is 13 bits wide. The low byte is called the PCL register. This register is readable and writable. The high byte is called the PCH register. This register contains the PC<12:8> bits and is not directly readable or writable. If the program counter (PC) is modified or a conditional test is true, the instruction requires two cycles. The second cycle is executed as a NOP. All updates to the PCH register go through the PCLATH register.

2.4.1 STACK

The stack allows a combination of up to 8 program calls and interrupts to occur. The stack contains the return address from this branch in program execution.

Mid-range devices have an 8 level deep x 13-bit wide hardware stack. The stack space is not part of either program or data space and the stack pointer is not readable or writable. The PC is PUSHed onto the stack when a CALL instruction is executed or an interrupt causes a branch. The stack is POPed in the event of a RETURN, RETLW or a RETFIE instruction execution. PCLATH is not modified when the stack is PUSHed or POPed.

After the stack has been PUSHed eight times, the ninth push overwrites the value that was stored from the first push. The tenth push overwrites the second push (and so on).

2.5 Indirect Addressing; INDF and FSR Registers

The INDF register is not a physical register. Addressing INDF actually addresses the register whose address is contained in the FSR register (FSR is a *pointer*). This is indirect addressing.

EXAMPLE 2-1: INDIRECT ADDRESSING

- Register file 05 contains the value 10h
- Register file 06 contains the value 0Ah
- Load the value 05 into the FSR register
- A read of the INDF register will return the value of 10h
- Increment the value of the FSR register by one (FSR = 06)
- A read of the INDF register now will return the value of 0Ah.

Reading INDF itself indirectly (FSR = 0) will produce 00h. Writing to the INDF register indirectly results in a no-operation (although STATUS bits may be affected).

A simple program to clear RAM locations 20h-2Fh using indirect addressing is shown in Example 2-2.

EXAMPLE 2-2: HOW TO CLEAR RAM USING INDIRECT ADDRESSING

```

        movlw  0x20    ;initialize pointer
        movwf  FSR     ;to RAM
NEXT    clrfs  INDF    ;clear INDF register
        incf   FSR     ;inc pointer
        btfss FSR,4   ;all done?
        goto  NEXT    ;NO, clear next
CONTINUE
        :             ;YES, continue
    
```

An effective 9-bit address is obtained by concatenating the 8-bit FSR register and the IRP bit (STATUS<7>), as shown in Figure 2-3. However, IRP is not used in the PIC16F84A.

PIC16F84A

FIGURE 2-3: DIRECT/INDIRECT ADDRESSING

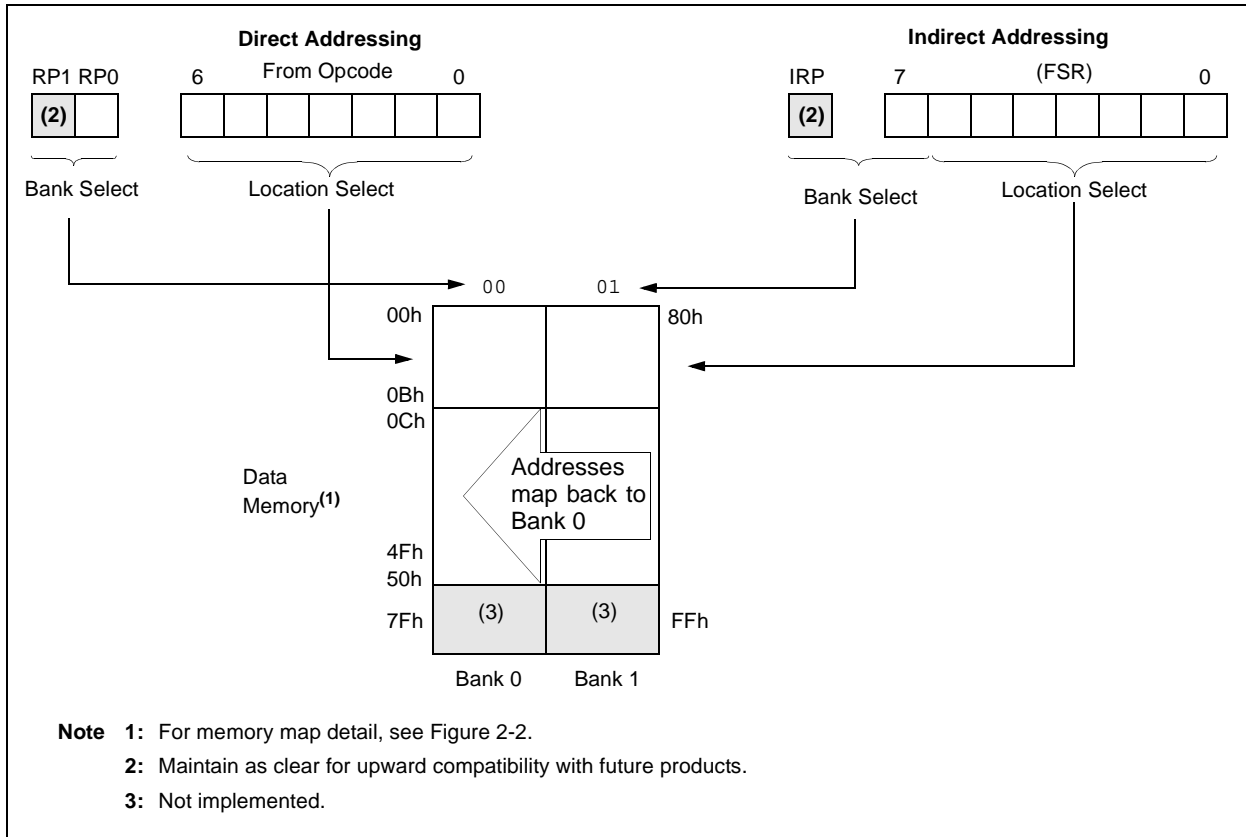

3.0 DATA EEPROM MEMORY

The EEPROM data memory is readable and writable during normal operation (full VDD range). This memory is not directly mapped in the register file space. Instead it is indirectly addressed through the Special Function Registers. There are four SFRs used to read and write this memory. These registers are:

- EECON1
- EECON2 (not a physically implemented register)
- EEDATA
- EEADR

EEDATA holds the 8-bit data for read/write, and EEADR holds the address of the EEPROM location being accessed. PIC16F84A devices have 64 bytes of data EEPROM with an address range from 0h to 3Fh.

The EEPROM data memory allows byte read and write. A byte write automatically erases the location and writes the new data (erase before write). The EEPROM data memory is rated for high erase/write cycles. The write time is controlled by an on-chip timer. The write-time will vary with voltage and temperature as well as from chip to chip. Please refer to AC specifications for exact limits.

When the device is code protected, the CPU may continue to read and write the data EEPROM memory. The device programmer can no longer access this memory.

Additional information on the Data EEPROM is available in the PICmicro™ Mid-Range Reference Manual (DS33023).

REGISTER 3-1: EECON1 REGISTER (ADDRESS 88h)

U-0	U-0	U-0	R/W-0	R/W-x	R/W-0	R/S-0	R/S-0	
—	—	—	EEIF	WRERR	WREN	WR	RD	
bit 7								bit 0

bit 7-5 **Unimplemented:** Read as '0'

bit 4 **EEIF:** EEPROM Write Operation Interrupt Flag bit

- 1 = The write operation completed (must be cleared in software)
- 0 = The write operation is not complete or has not been started

bit 3 **WRERR:** EEPROM Error Flag bit

- 1 = A write operation is prematurely terminated (any MCLR Reset or any WDT Reset during normal operation)
- 0 = The write operation completed

bit 2 **WREN:** EEPROM Write Enable bit

- 1 = Allows write cycles
- 0 = Inhibits write to the EEPROM

bit 1 **WR:** Write Control bit

- 1 = Initiates a write cycle. The bit is cleared by hardware once write is complete. The WR bit can only be set (not cleared) in software.
- 0 = Write cycle to the EEPROM is complete

bit 0 **RD:** Read Control bit

- 1 = Initiates an EEPROM read RD is cleared in hardware. The RD bit can only be set (not cleared) in software.
- 0 = Does not initiate an EEPROM read

Legend:

R = Readable bit	W = Writable bit	U = Unimplemented bit, read as '0'
- n = Value at POR	'1' = Bit is set	'0' = Bit is cleared x = Bit is unknown

PIC16F84A

3.1 Reading the EEPROM Data Memory

To read a data memory location, the user must write the address to the EEADR register and then set control bit RD (EECON1<0>). The data is available, in the very next cycle, in the EEDATA register; therefore, it can be read in the next instruction. EEDATA will hold this value until another read or until it is written to by the user (during a write operation).

EXAMPLE 3-1: DATA EEPROM READ

```
BCF    STATUS, RP0 ; Bank 0
MOVLW CONFIG_ADDR ;
MOVWF  EEADR      ; Address to read
BSF    STATUS, RP0 ; Bank 1
BSF    EECON1, RD ; EE Read
BCF    STATUS, RP0 ; Bank 0
MOVF   EEDATA, W  ; W = EEDATA
```

3.2 Writing to the EEPROM Data Memory

To write an EEPROM data location, the user must first write the address to the EEADR register and the data to the EEDATA register. Then the user must follow a specific sequence to initiate the write for each byte.

EXAMPLE 3-2: DATA EEPROM WRITE

```
BSF    STATUS, RP0 ; Bank 1
BSF    INTCON, GIE ; Disable INTs.
BSF    EECON1, WREN ; Enable Write
MOVLW  55h        ;
MOVWF  EECON2     ; Write 55h
MOVLW  AAh        ;
MOVWF  EECON2     ; Write AAh
BSF    EECON1, WR ; Set WR bit
                ; begin write
BSF    INTCON, GIE ; Enable INTs.
```

The write will not initiate if the above sequence is not exactly followed (write 55h to EECON2, write AAh to EECON2, then set WR bit) for each byte. We strongly recommend that interrupts be disabled during this code segment.

Additionally, the WREN bit in EECON1 must be set to enable write. This mechanism prevents accidental writes to data EEPROM due to errant (unexpected) code execution (i.e., lost programs). The user should keep the WREN bit clear at all times, except when updating EEPROM. The WREN bit is not cleared by hardware.

After a write sequence has been initiated, clearing the WREN bit will not affect this write cycle. The WR bit will be inhibited from being set unless the WREN bit is set.

At the completion of the write cycle, the WR bit is cleared in hardware and the EE Write Complete Interrupt Flag bit (EEIF) is set. The user can either enable this interrupt or poll this bit. EEIF must be cleared by software.

3.3 Write Verify

Depending on the application, good programming practice may dictate that the value written to the Data EEPROM should be verified (Example 3-3) to the desired value to be written. This should be used in applications where an EEPROM bit will be stressed near the specification limit.

Generally, the EEPROM write failure will be a bit which was written as a '0', but reads back as a '1' (due to leakage off the bit).

EXAMPLE 3-3: WRITE VERIFY

```
BCF    STATUS, RP0 ; Bank 0
:      ; Any code
:      ; can go here
MOVF   EEDATA, W  ; Must be in Bank 0
BSF    STATUS, RP0 ; Bank 1
READ
BSF    EECON1, RD ; YES, Read the
                ; value written
BCF    STATUS, RP0 ; Bank 0
                ;
                ; Is the value written
                ; (in W reg) and
                ; read (in EEDATA)
                ; the same?
                ;
SUBWF  EEDATA, W  ;
BTFS   STATUS, Z  ; Is difference 0?
GOTO   WRITE_ERR ; NO, Write error
```

TABLE 3-1: REGISTERS/BITS ASSOCIATED WITH DATA EEPROM

Address	Name	Bit 7	Bit 6	Bit 5	Bit 4	Bit 3	Bit 2	Bit 1	Bit 0	Value on Power-on Reset	Value on all other RESETS
08h	EEDATA	EEPROM Data Register								xxxx xxxx	uuuu uuuu
09h	EEADR	EEPROM Address Register								xxxx xxxx	uuuu uuuu
88h	EECON1	—	—	—	EEIF	WRERR	WREN	WR	RD	---0 x000	---0 q000
89h	EECON2	EEPROM Control Register 2								----	----

Legend: x = unknown, u = unchanged, - = unimplemented, read as '0', q = value depends upon condition.

Shaded cells are not used by data EEPROM.

4.0 I/O PORTS

Some pins for these I/O ports are multiplexed with an alternate function for the peripheral features on the device. In general, when a peripheral is enabled, that pin may not be used as a general purpose I/O pin.

Additional information on I/O ports may be found in the PICmicro™ Mid-Range Reference Manual (DS33023).

4.1 PORTA and TRISA Registers

PORTA is a 5-bit wide, bi-directional port. The corresponding data direction register is TRISA. Setting a TRISA bit (= 1) will make the corresponding PORTA pin an input (i.e., put the corresponding output driver in a Hi-Impedance mode). Clearing a TRISA bit (= 0) will make the corresponding PORTA pin an output (i.e., put the contents of the output latch on the selected pin).

Note: On a Power-on Reset, these pins are configured as inputs and read as '0'.

Reading the PORTA register reads the status of the pins, whereas writing to it will write to the port latch. All write operations are read-modify-write operations. Therefore, a write to a port implies that the port pins are read. This value is modified and then written to the port data latch.

Pin RA4 is multiplexed with the Timer0 module clock input to become the RA4/T0CKI pin. The RA4/T0CKI pin is a Schmitt Trigger input and an open drain output. All other RA port pins have TTL input levels and full CMOS output drivers.

EXAMPLE 4-1: INITIALIZING PORTA

```
BCF STATUS, RP0 ;
CLRF PORTA      ; Initialize PORTA by
                ; clearing output
                ; data latches
BSF STATUS, RP0 ; Select Bank 1
MOVLW 0x0F     ; Value used to
                ; initialize data
                ; direction
MOVWF TRISA    ; Set RA<3:0> as inputs
                ; RA4 as output
                ; TRISA<7:5> are always
                ; read as '0'.
```

FIGURE 4-1: BLOCK DIAGRAM OF PINS RA3:RA0

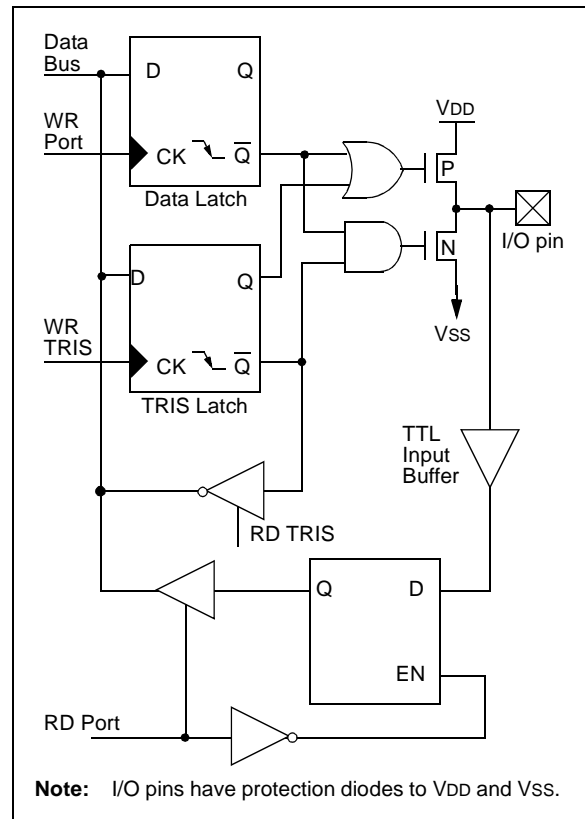

Note: I/O pins have protection diodes to VDD and VSS.

FIGURE 4-2: BLOCK DIAGRAM OF PIN RA4

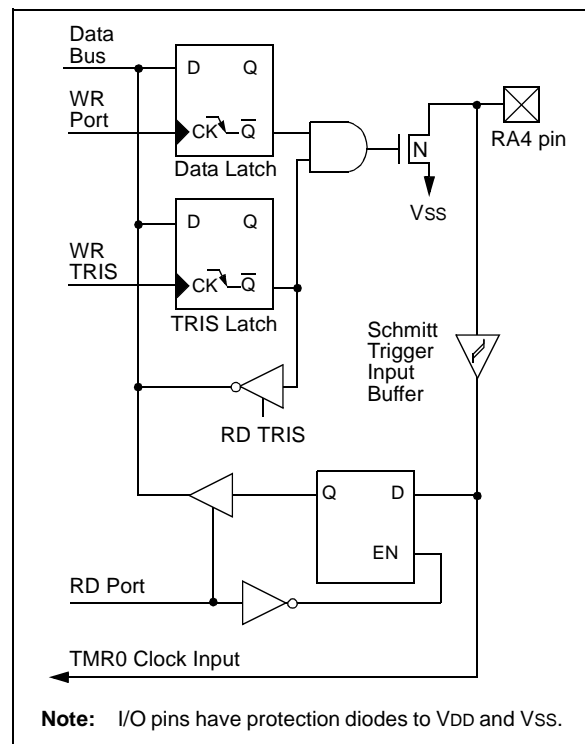

Note: I/O pins have protection diodes to VDD and VSS.

PIC16F84A

TABLE 4-1: PORTA FUNCTIONS

Name	Bit0	Buffer Type	Function
RA0	bit0	TTL	Input/output
RA1	bit1	TTL	Input/output
RA2	bit2	TTL	Input/output
RA3	bit3	TTL	Input/output
RA4/T0CKI	bit4	ST	Input/output or external clock input for TMR0. Output is open drain type.

Legend: TTL = TTL input, ST = Schmitt Trigger input

TABLE 4-2: SUMMARY OF REGISTERS ASSOCIATED WITH PORTA

Address	Name	Bit 7	Bit 6	Bit 5	Bit 4	Bit 3	Bit 2	Bit 1	Bit 0	Value on Power-on Reset	Value on all other RESETS
05h	PORTA	—	—	—	RA4/T0CKI	RA3	RA2	RA1	RA0	---x xxxx	---u uuuu
85h	TRISA	—	—	—	TRISA4	TRISA3	TRISA2	TRISA1	TRISA0	---1 1111	---1 1111

Legend: x = unknown, u = unchanged, - = unimplemented, read as '0'. Shaded cells are unimplemented, read as '0'.

4.2 PORTB and TRISB Registers

PORTB is an 8-bit wide, bi-directional port. The corresponding data direction register is TRISB. Setting a TRISB bit (= 1) will make the corresponding PORTB pin an input (i.e., put the corresponding output driver in a Hi-Impedance mode). Clearing a TRISB bit (= 0) will make the corresponding PORTB pin an output (i.e., put the contents of the output latch on the selected pin).

EXAMPLE 4-2: INITIALIZING PORTB

```
BCF    STATUS, RP0 ;
CLRF  PORTB      ; Initialize PORTB by
                ; clearing output
                ; data latches
BSF    STATUS, RP0 ; Select Bank 1
MOVLW 0xCF      ; Value used to
                ; initialize data
                ; direction
MOVWF  TRISB     ; Set RB<3:0> as inputs
                ; RB<5:4> as outputs
                ; RB<7:6> as inputs
```

Each of the PORTB pins has a weak internal pull-up. A single control bit can turn on all the pull-ups. This is performed by clearing bit $\overline{\text{RBP}}\text{U}$ (OPTION<7>). The weak pull-up is automatically turned off when the port pin is configured as an output. The pull-ups are disabled on a Power-on Reset.

Four of PORTB's pins, RB7:RB4, have an interrupt-on-change feature. Only pins configured as inputs can cause this interrupt to occur (i.e., any RB7:RB4 pin configured as an output is excluded from the interrupt-on-change comparison). The input pins (of RB7:RB4) are compared with the old value latched on the last read of PORTB. The "mismatch" outputs of RB7:RB4 are OR'ed together to generate the RB Port Change Interrupt with flag bit RBIF (INTCON<0>).

This interrupt can wake the device from SLEEP. The user, in the Interrupt Service Routine, can clear the interrupt in the following manner:

- Any read or write of PORTB. This will end the mismatch condition.
- Clear flag bit RBIF.

A mismatch condition will continue to set flag bit RBIF. Reading PORTB will end the mismatch condition and allow flag bit RBIF to be cleared.

The interrupt-on-change feature is recommended for wake-up on key depression operation and operations where PORTB is only used for the interrupt-on-change feature. Polling of PORTB is not recommended while using the interrupt-on-change feature.

FIGURE 4-3: BLOCK DIAGRAM OF PINS RB7:RB4

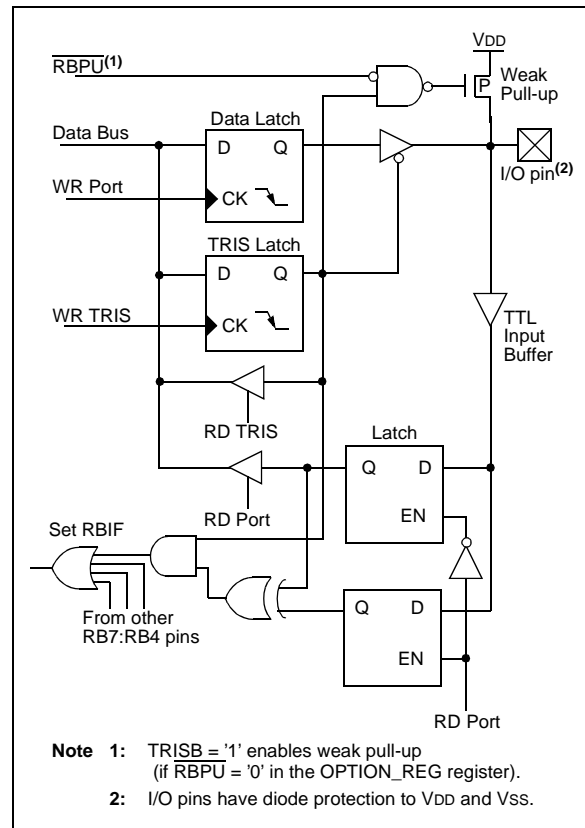
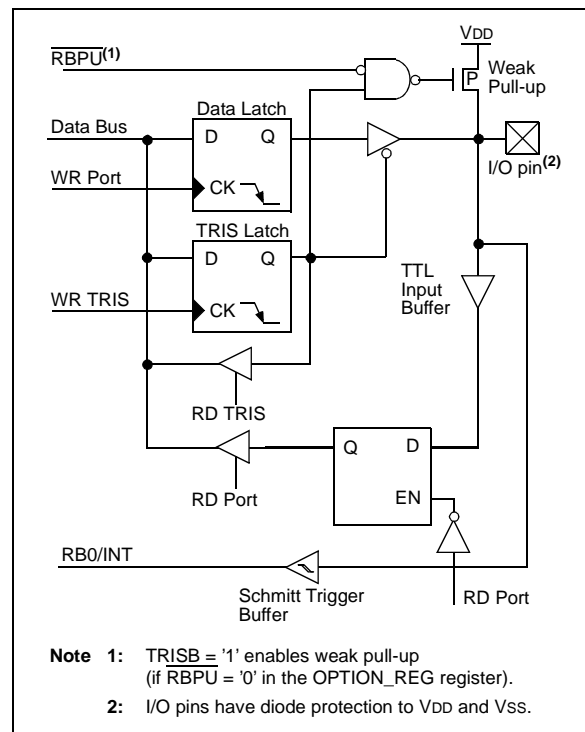

FIGURE 4-4: BLOCK DIAGRAM OF PINS RB3:RB0



PIC16F84A

TABLE 4-3: PORTB FUNCTIONS

Name	Bit	Buffer Type	I/O Consistency Function
RB0/INT	bit0	TTL/ST ⁽¹⁾	Input/output pin or external interrupt input. Internal software programmable weak pull-up.
RB1	bit1	TTL	Input/output pin. Internal software programmable weak pull-up.
RB2	bit2	TTL	Input/output pin. Internal software programmable weak pull-up.
RB3	bit3	TTL	Input/output pin. Internal software programmable weak pull-up.
RB4	bit4	TTL	Input/output pin (with interrupt-on-change). Internal software programmable weak pull-up.
RB5	bit5	TTL	Input/output pin (with interrupt-on-change). Internal software programmable weak pull-up.
RB6	bit6	TTL/ST ⁽²⁾	Input/output pin (with interrupt-on-change). Internal software programmable weak pull-up. Serial programming clock.
RB7	bit7	TTL/ST ⁽²⁾	Input/output pin (with interrupt-on-change). Internal software programmable weak pull-up. Serial programming data.

Legend: TTL = TTL input, ST = Schmitt Trigger.

Note 1: This buffer is a Schmitt Trigger input when configured as the external interrupt.

2: This buffer is a Schmitt Trigger input when used in Serial Programming mode.

TABLE 4-4: SUMMARY OF REGISTERS ASSOCIATED WITH PORTB

Address	Name	Bit 7	Bit 6	Bit 5	Bit 4	Bit 3	Bit 2	Bit 1	Bit 0	Value on Power-on Reset	Value on all other RESETS
06h	PORTB	RB7	RB6	RB5	RB4	RB3	RB2	RB1	RB0/INT	xxxx xxxx	uuuu uuuu
86h	TRISB	TRISB7	TRISB6	TRISB5	TRISB4	TRISB3	TRISB2	TRISB1	TRISB0	1111 1111	1111 1111
81h	OPTION_REG	RBPU	INTEDG	T0CS	T0SE	PSA	PS2	PS1	PS0	1111 1111	1111 1111
0Bh,8Bh	INTCON	GIE	EEIE	T0IE	INTE	RBIE	T0IF	INTF	RBIF	0000 000x	0000 000u

Legend: x = unknown, u = unchanged. Shaded cells are not used by PORTB.

5.0 TIMER0 MODULE

The Timer0 module timer/counter has the following features:

- 8-bit timer/counter
- Readable and writable
- Internal or external clock select
- Edge select for external clock
- 8-bit software programmable prescaler
- Interrupt-on-overflow from FFh to 00h

Figure 5-1 is a simplified block diagram of the Timer0 module.

Additional information on timer modules is available in the PICmicro™ Mid-Range Reference Manual (DS33023).

5.1 Timer0 Operation

Timer0 can operate as a timer or as a counter.

Timer mode is selected by clearing bit T0CS (OPTION_REG<5>). In Timer mode, the Timer0 module will increment every instruction cycle (without prescaler). If the TMR0 register is written, the increment is inhibited for the following two instruction cycles. The user can work around this by writing an adjusted value to the TMR0 register.

Counter mode is selected by setting bit T0CS (OPTION_REG<5>). In Counter mode, Timer0 will increment, either on every rising or falling edge of pin RA4/T0CKI. The incrementing edge is determined by the Timer0 Source Edge Select bit, T0SE (OPTION_REG<4>). Clearing bit T0SE selects the rising edge. Restrictions on the external clock input are discussed below.

When an external clock input is used for Timer0, it must meet certain requirements. The requirements ensure the external clock can be synchronized with the internal phase clock (TOSC). Also, there is a delay in the actual incrementing of Timer0 after synchronization.

Additional information on external clock requirements is available in the PICmicro™ Mid-Range Reference Manual, (DS33023).

5.2 Prescaler

An 8-bit counter is available as a prescaler for the Timer0 module, or as a postscaler for the Watchdog Timer, respectively (Figure 5-2). For simplicity, this counter is being referred to as “prescaler” throughout this data sheet. Note that there is only one prescaler available which is mutually exclusively shared between the Timer0 module and the Watchdog Timer. Thus, a prescaler assignment for the Timer0 module means that there is no prescaler for the Watchdog Timer, and vice-versa.

The prescaler is not readable or writable.

The PSA and PS2:PS0 bits (OPTION_REG<3:0>) determine the prescaler assignment and prescale ratio.

Clearing bit PSA will assign the prescaler to the Timer0 module. When the prescaler is assigned to the Timer0 module, prescale values of 1:2, 1:4, ..., 1:256 are selectable.

Setting bit PSA will assign the prescaler to the Watchdog Timer (WDT). When the prescaler is assigned to the WDT, prescale values of 1:1, 1:2, ..., 1:128 are selectable.

When assigned to the Timer0 module, all instructions writing to the TMR0 register (e.g., CLRF 1, MOVWF 1, BSF 1, etc.) will clear the prescaler. When assigned to WDT, a CLRWDT instruction will clear the prescaler along with the WDT.

Note: Writing to TMR0 when the prescaler is assigned to Timer0 will clear the prescaler count, but will not change the prescaler assignment.

FIGURE 5-1: TIMER0 BLOCK DIAGRAM

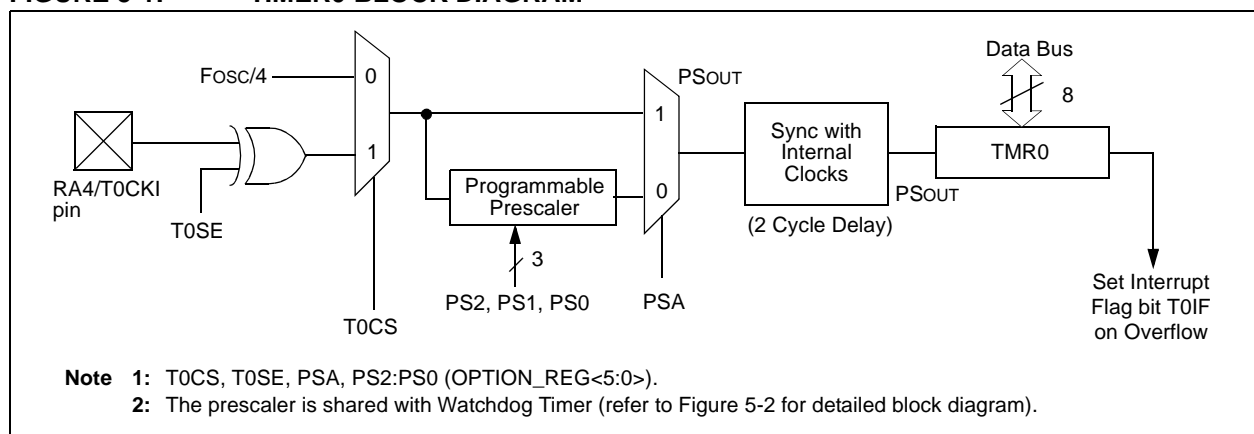

PIC16F84A

5.2.1 SWITCHING PRESCALER ASSIGNMENT

The prescaler assignment is fully under software control (i.e., it can be changed “on the fly” during program execution).

Note: To avoid an unintended device RESET, a specific instruction sequence (shown in the PICmicro™ Mid-Range Reference Manual, DS33023) must be executed when changing the prescaler assignment from Timer0 to the WDT. This sequence must be followed even if the WDT is disabled.

5.3 Timer0 Interrupt

The TMR0 interrupt is generated when the TMR0 register overflows from FFh to 00h. This overflow sets bit T0IF (INTCON<2>). The interrupt can be masked by clearing bit T0IE (INTCON<5>). Bit T0IF must be cleared in software by the Timer0 module Interrupt Service Routine before re-enabling this interrupt. The TMR0 interrupt cannot awaken the processor from SLEEP since the timer is shut-off during SLEEP.

FIGURE 5-2: BLOCK DIAGRAM OF THE TIMER0/WDT PRESCALER

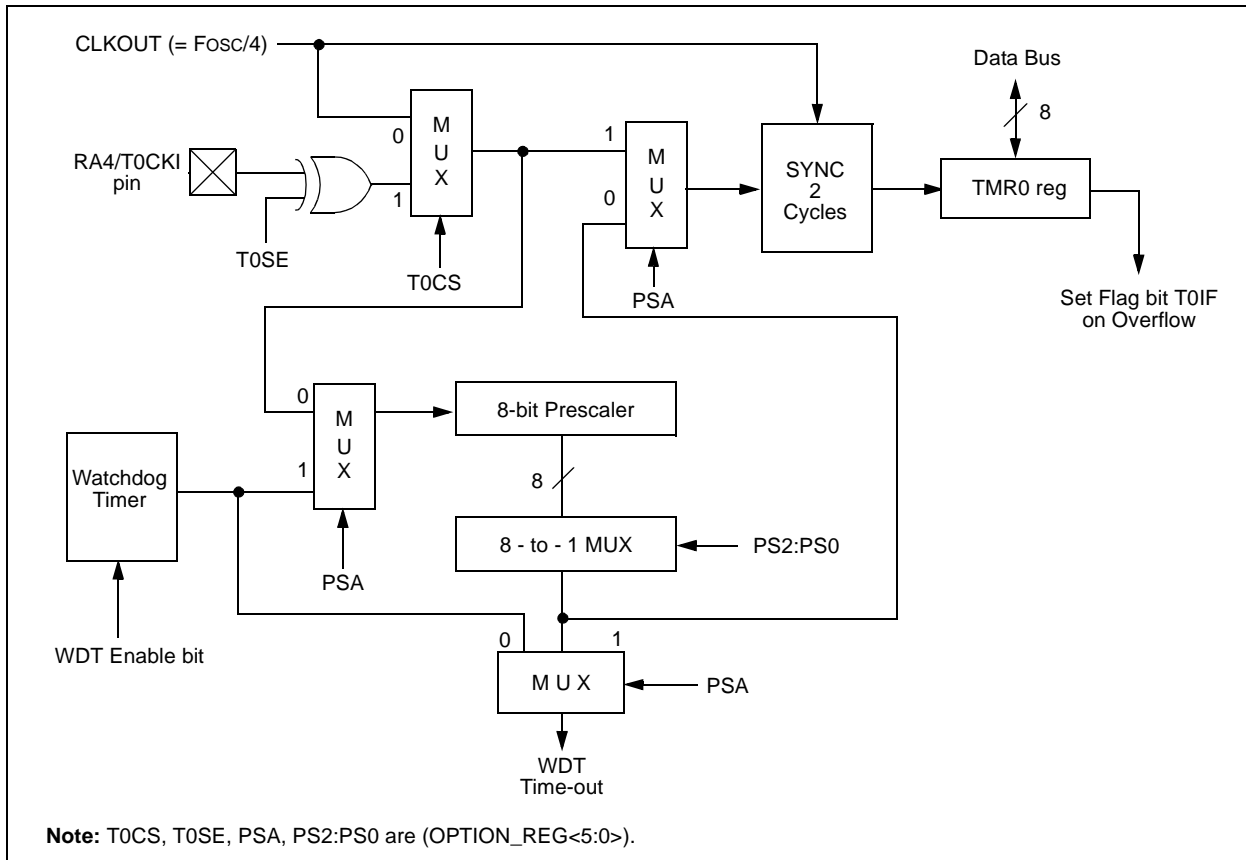

TABLE 5-1: REGISTERS ASSOCIATED WITH TIMER0

Address	Name	Bit 7	Bit 6	Bit 5	Bit 4	Bit 3	Bit 2	Bit 1	Bit 0	Value on POR, BOR	Value on all other RESETS
01h	TMR0	Timer0 Module Register								xxxx xxxx	uuuu uuuu
0Bh,8Bh	INTCON	GIE	EEIE	T0IE	INTE	RBIE	T0IF	INTF	RBIF	0000 000x	0000 000u
81h	OPTION_REG	RBPU	INTEDG	T0CS	T0SE	PSA	PS2	PS1	PS0	1111 1111	1111 1111
85h	TRISA	—	—	—	PORTA Data Direction Register				---	1111	---1 1111

Legend: x = unknown, u = unchanged, - = unimplemented locations read as '0'. Shaded cells are not used by Timer0.

6.0 SPECIAL FEATURES OF THE CPU

What sets a microcontroller apart from other processors are special circuits to deal with the needs of real time applications. The PIC16F84A has a host of such features intended to maximize system reliability, minimize cost through elimination of external components, provide power saving operating modes and offer code protection. These features are:

- OSC Selection
- RESET
 - Power-on Reset (POR)
 - Power-up Timer (PWRT)
 - Oscillator Start-up Timer (OST)
- Interrupts
- Watchdog Timer (WDT)
- SLEEP
- Code Protection
- ID Locations
- In-Circuit Serial Programming™ (ICSP™)

The PIC16F84A has a Watchdog Timer which can be shut-off only through configuration bits. It runs off its own RC oscillator for added reliability. There are two timers that offer necessary delays on power-up. One is the Oscillator Start-up Timer (OST), intended to keep

the chip in RESET until the crystal oscillator is stable. The other is the Power-up Timer (PWRT), which provides a fixed delay of 72 ms (nominal) on power-up only. This design keeps the device in RESET while the power supply stabilizes. With these two timers on-chip, most applications need no external RESET circuitry.

SLEEP mode offers a very low current power-down mode. The user can wake-up from SLEEP through external RESET, Watchdog Timer Time-out or through an interrupt. Several oscillator options are provided to allow the part to fit the application. The RC oscillator option saves system cost while the LP crystal option saves power. A set of configuration bits are used to select the various options.

Additional information on special features is available in the PICmicro™ Mid-Range Reference Manual (DS33023).

6.1 Configuration Bits

The configuration bits can be programmed (read as '0'), or left unprogrammed (read as '1'), to select various device configurations. These bits are mapped in program memory location 2007h.

Address 2007h is beyond the user program memory space and it belongs to the special test/configuration memory space (2000h - 3FFFh). This space can only be accessed during programming.

REGISTER 6-1: PIC16F84A CONFIGURATION WORD

R/P-u	R/P-u	R/P-u	R/P-u	R/P-u	R/P-u	R/P-u	R/P-u	R/P-u	R/P-u	R/P-u	R/P-u	R/P-u	R/P-u	R/P-u
CP	CP	CP	CP	CP	CP	CP	CP	CP	CP	PWRTÉ	WDTE	F0SC1	F0SC0	
bit13											bit0			

- bit 13-4 **CP:** Code Protection bit
 1 = Code protection disabled
 0 = All program memory is code protected
- bit 3 **PWRTÉ:** Power-up Timer Enable bit
 1 = Power-up Timer is disabled
 0 = Power-up Timer is enabled
- bit 2 **WDTE:** Watchdog Timer Enable bit
 1 = WDT enabled
 0 = WDT disabled
- bit 1-0 **FOSC1:FOSC0:** Oscillator Selection bits
 11 = RC oscillator
 10 = HS oscillator
 01 = XT oscillator
 00 = LP oscillator

PIC16F84A

6.2 Oscillator Configurations

6.2.1 OSCILLATOR TYPES

The PIC16F84A can be operated in four different oscillator modes. The user can program two configuration bits (FOSC1 and FOSC0) to select one of these four modes:

- LP Low Power Crystal
- XT Crystal/Resonator
- HS High Speed Crystal/Resonator
- RC Resistor/Capacitor

6.2.2 CRYSTAL OSCILLATOR/CERAMIC RESONATORS

In XT, LP, or HS modes, a crystal or ceramic resonator is connected to the OSC1/CLKIN and OSC2/CLKOUT pins to establish oscillation (Figure 6-1).

FIGURE 6-1: CRYSTAL/CERAMIC RESONATOR OPERATION (HS, XT OR LP OSC CONFIGURATION)

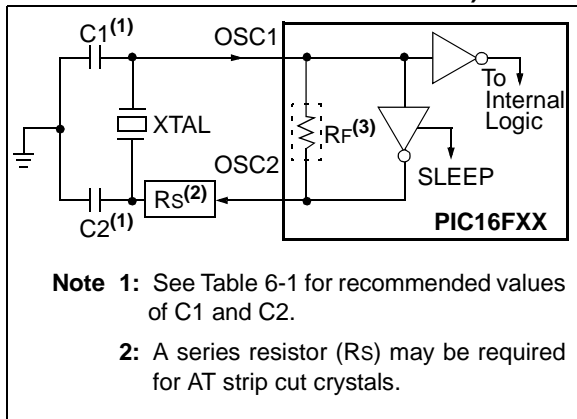

The PIC16F84A oscillator design requires the use of a parallel cut crystal. Use of a series cut crystal may give a frequency out of the crystal manufacturers specifications. When in XT, LP, or HS modes, the device can have an external clock source to drive the OSC1/CLKIN pin (Figure 6-2).

FIGURE 6-2: EXTERNAL CLOCK INPUT OPERATION (HS, XT OR LP OSC CONFIGURATION)

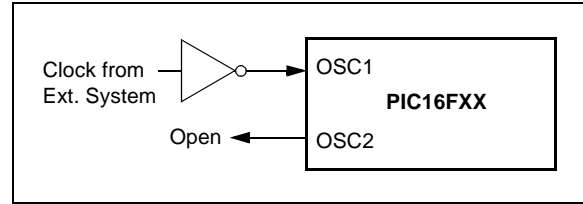

TABLE 6-1: CAPACITOR SELECTION FOR CERAMIC RESONATORS

Ranges Tested:			
Mode	Freq	OSC1/C1	OSC2/C2
XT	455 kHz	47 - 100 pF	47 - 100 pF
	2.0 MHz	15 - 33 pF	15 - 33 pF
	4.0 MHz	15 - 33 pF	15 - 33 pF
HS	8.0 MHz	15 - 33 pF	15 - 33 pF
	10.0 MHz	15 - 33 pF	15 - 33 pF

Note: Recommended values of C1 and C2 are identical to the ranges tested in this table. Higher capacitance increases the stability of the oscillator, but also increases the start-up time. These values are for design guidance only. Since each resonator has its own characteristics, the user should consult the resonator manufacturer for the appropriate values of external components.

Note: When using resonators with frequencies above 3.5 MHz, the use of HS mode rather than XT mode, is recommended. HS mode may be used at any VDD for which the controller is rated.

TABLE 6-2: CAPACITOR SELECTION FOR CRYSTAL OSCILLATOR

Mode	Freq	OSC1/C1	OSC2/C2
LP	32 kHz	68 - 100 pF	68 - 100 pF
	200 kHz	15 - 33 pF	15 - 33 pF
XT	100 kHz	100 - 150 pF	100 - 150 pF
	2 MHz	15 - 33 pF	15 - 33 pF
	4 MHz	15 - 33 pF	15 - 33 pF
HS	4 MHz	15 - 33 pF	15 - 33 pF
	20 MHz	15 - 33 pF	15 - 33 pF

Note: Higher capacitance increases the stability of the oscillator, but also increases the start-up time. These values are for design guidance only. Rs may be required in HS mode, as well as XT mode, to avoid overdriving crystals with low drive level specification. Since each crystal has its own characteristics, the user should consult the crystal manufacturer for appropriate values of external components. For $V_{DD} > 4.5V$, $C1 = C2 \approx 30 pF$ is recommended.

6.2.3 RC OSCILLATOR

For timing insensitive applications, the RC device option offers additional cost savings. The RC oscillator frequency is a function of the supply voltage, the resistor (R_{EXT}) values, capacitor (C_{EXT}) values, and the operating temperature. In addition to this, the oscillator frequency will vary from unit to unit due to normal process parameter variation. Furthermore, the difference in lead frame capacitance between package types also affects the oscillation frequency, especially for low C_{EXT} values. The user needs to take into account variation, due to tolerance of the external R and C components. Figure 6-3 shows how an R/C combination is connected to the PIC16F84A.

FIGURE 6-3: RC OSCILLATOR MODE

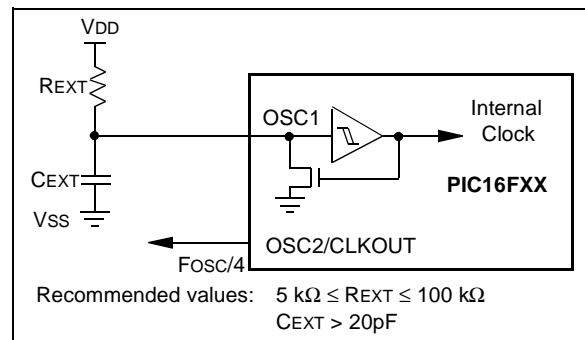

PIC16F84A

6.3 RESET

The PIC16F84A differentiates between various kinds of RESET:

- Power-on Reset (POR)
- $\overline{\text{MCLR}}$ during normal operation
- $\overline{\text{MCLR}}$ during SLEEP
- WDT Reset (during normal operation)
- WDT Wake-up (during SLEEP)

Figure 6-4 shows a simplified block diagram of the On-Chip RESET Circuit. The $\overline{\text{MCLR}}$ Reset path has a noise filter to ignore small pulses. The electrical specifications state the pulse width requirements for the $\overline{\text{MCLR}}$ pin.

Some registers are not affected in any RESET condition; their status is unknown on a POR and unchanged in any other RESET. Most other registers are reset to a "RESET state" on POR, $\overline{\text{MCLR}}$ or WDT Reset during normal operation and on $\overline{\text{MCLR}}$ during SLEEP. They are not affected by a WDT Reset during SLEEP, since this RESET is viewed as the resumption of normal operation.

Table 6-3 gives a description of RESET conditions for the program counter (PC) and the STATUS register. Table 6-4 gives a full description of RESET states for all registers.

The $\overline{\text{TO}}$ and $\overline{\text{PD}}$ bits are set or cleared differently in different RESET situations (Section 6.7). These bits are used in software to determine the nature of the RESET.

FIGURE 6-4: SIMPLIFIED BLOCK DIAGRAM OF ON-CHIP RESET CIRCUIT

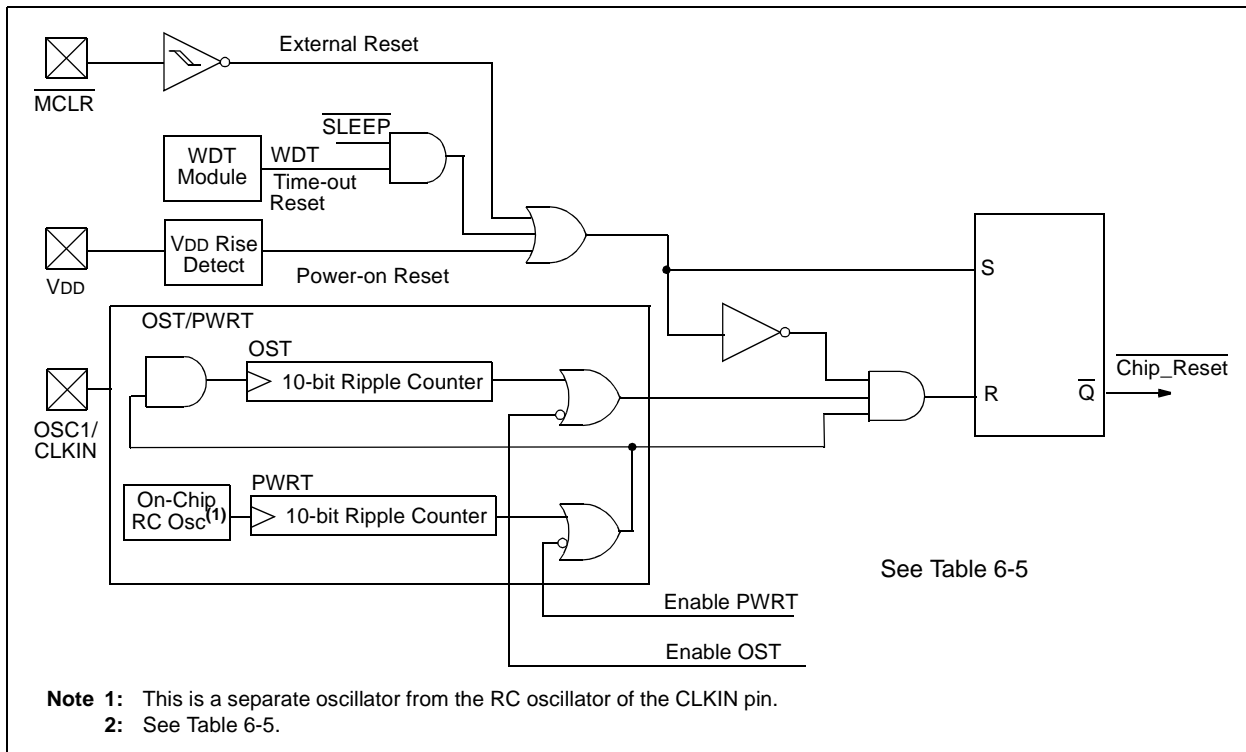

TABLE 6-3: RESET CONDITION FOR PROGRAM COUNTER AND THE STATUS REGISTER

Condition	Program Counter	STATUS Register
Power-on Reset	000h	0001 1xxx
$\overline{\text{MCLR}}$ during normal operation	000h	000u uuuu
$\overline{\text{MCLR}}$ during SLEEP	000h	0001 0uuu
WDT Reset (during normal operation)	000h	0000 1uuu
WDT Wake-up	PC + 1	uuu0 0uuu
Interrupt wake-up from SLEEP	PC + 1 ⁽¹⁾	uuu1 0uuu

Legend: u = unchanged, x = unknown

Note 1: When the wake-up is due to an interrupt and the GIE bit is set, the PC is loaded with the interrupt vector (0004h).

TABLE 6-4: RESET CONDITIONS FOR ALL REGISTERS

Register	Address	Power-on Reset	MCLR during: – normal operation – SLEEP WDT Reset during normal operation	Wake-up from SLEEP: – through interrupt – through WDT Time-out
W	—	xxxx xxxx	uuuu uuuu	uuuu uuuu
INDF	00h	---- ----	---- ----	---- ----
TMR0	01h	xxxx xxxx	uuuu uuuu	uuuu uuuu
PCL	02h	0000 0000	0000 0000	PC + 1 ⁽²⁾
STATUS	03h	0001 1xxx	000q quuu ⁽³⁾	uuuq quuu ⁽³⁾
FSR	04h	xxxx xxxx	uuuu uuuu	uuuu uuuu
PORTA ⁽⁴⁾	05h	---x xxxx	---u uuuu	---u uuuu
PORTB ⁽⁵⁾	06h	xxxx xxxx	uuuu uuuu	uuuu uuuu
EEDATA	08h	xxxx xxxx	uuuu uuuu	uuuu uuuu
EEADR	09h	xxxx xxxx	uuuu uuuu	uuuu uuuu
PCLATH	0Ah	---0 0000	---0 0000	---u uuuu
INTCON	0Bh	0000 000x	0000 000u	uuuu uuuu ⁽¹⁾
INDF	80h	---- ----	---- ----	---- ----
OPTION_REG	81h	1111 1111	1111 1111	uuuu uuuu
PCL	82h	0000 0000	0000 0000	PC + 1 ⁽²⁾
STATUS	83h	0001 1xxx	000q quuu ⁽³⁾	uuuq quuu ⁽³⁾
FSR	84h	xxxx xxxx	uuuu uuuu	uuuu uuuu
TRISA	85h	---1 1111	---1 1111	---u uuuu
TRISB	86h	1111 1111	1111 1111	uuuu uuuu
EECON1	88h	---0 x000	---0 q000	---0 uuuu
EECON2	89h	---- ----	---- ----	---- ----
PCLATH	8Ah	---0 0000	---0 0000	---u uuuu
INTCON	8Bh	0000 000x	0000 000u	uuuu uuuu ⁽¹⁾

Legend: u = unchanged, x = unknown, - = unimplemented bit, read as '0', q = value depends on condition

Note 1: One or more bits in INTCON will be affected (to cause wake-up).

2: When the wake-up is due to an interrupt and the GIE bit is set, the PC is loaded with the interrupt vector (0004h).

3: Table 6-3 lists the RESET value for each specific condition.

4: On any device RESET, these pins are configured as inputs.

5: This is the value that will be in the port output latch.

PIC16F84A

6.4 Power-on Reset (POR)

A Power-on Reset pulse is generated on-chip when VDD rise is detected (in the range of 1.2V - 1.7V). To take advantage of the POR, just tie the $\overline{\text{MCLR}}$ pin directly (or through a resistor) to VDD. This will eliminate external RC components usually needed to create Power-on Reset. A minimum rise time for VDD must be met for this to operate properly. See Electrical Specifications for details.

When the device starts normal operation (exits the RESET condition), device operating parameters (voltage, frequency, temperature, etc.) must be met to ensure operation. If these conditions are not met, the device must be held in RESET until the operating conditions are met.

For additional information, refer to Application Note AN607, "Power-up Trouble Shooting."

The POR circuit does not produce an internal RESET when VDD declines.

6.5 Power-up Timer (PWRT)

The Power-up Timer (PWRT) provides a fixed 72 ms nominal time-out (TPWRT) from POR (Figures 6-6 through 6-9). The Power-up Timer operates on an internal RC oscillator. The chip is kept in RESET as long as the PWRT is active. The PWRT delay allows the VDD to rise to an acceptable level (possible exception shown in Figure 6-9).

A configuration bit, $\overline{\text{PWRTSE}}$, can enable/disable the PWRT. See Register 6-1 for the operation of the $\overline{\text{PWRTSE}}$ bit for a particular device.

The power-up time delay TPWRT will vary from chip to chip due to VDD, temperature, and process variation. See DC parameters for details.

6.6 Oscillator Start-up Timer (OST)

The Oscillator Start-up Timer (OST) provides a 1024 oscillator cycle delay (from OSC1 input) after the PWRT delay ends (Figure 6-6, Figure 6-7, Figure 6-8 and Figure 6-9). This ensures the crystal oscillator or resonator has started and stabilized.

The OST time-out (TOST) is invoked only for XT, LP and HS modes and only on Power-on Reset or wake-up from SLEEP.

When VDD rises very slowly, it is possible that the TPWRT time-out and TOST time-out will expire before VDD has reached its final value. In this case (Figure 6-9), an external Power-on Reset circuit may be necessary (Figure 6-5).

FIGURE 6-5: EXTERNAL POWER-ON RESET CIRCUIT (FOR SLOW VDD POWER-UP)

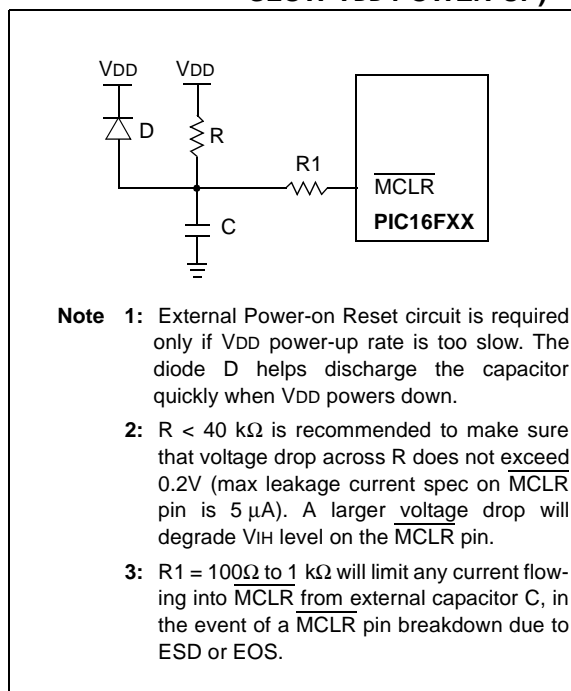

FIGURE 6-6: TIME-OUT SEQUENCE ON POWER-UP ($\overline{\text{MCLR}}$ NOT TIED TO V_{DD}): CASE 1

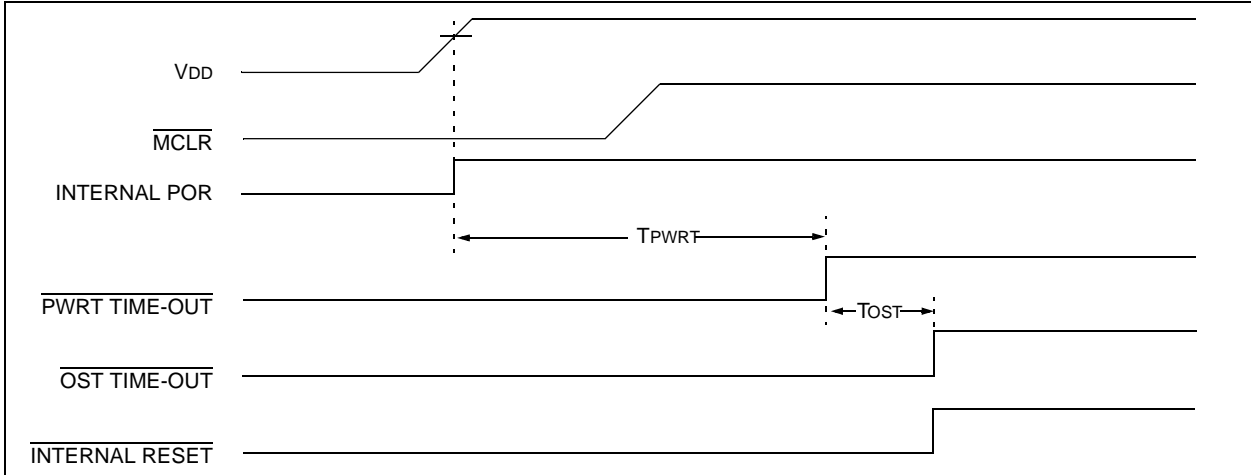

FIGURE 6-7: TIME-OUT SEQUENCE ON POWER-UP ($\overline{\text{MCLR}}$ NOT TIED TO V_{DD}): CASE 2

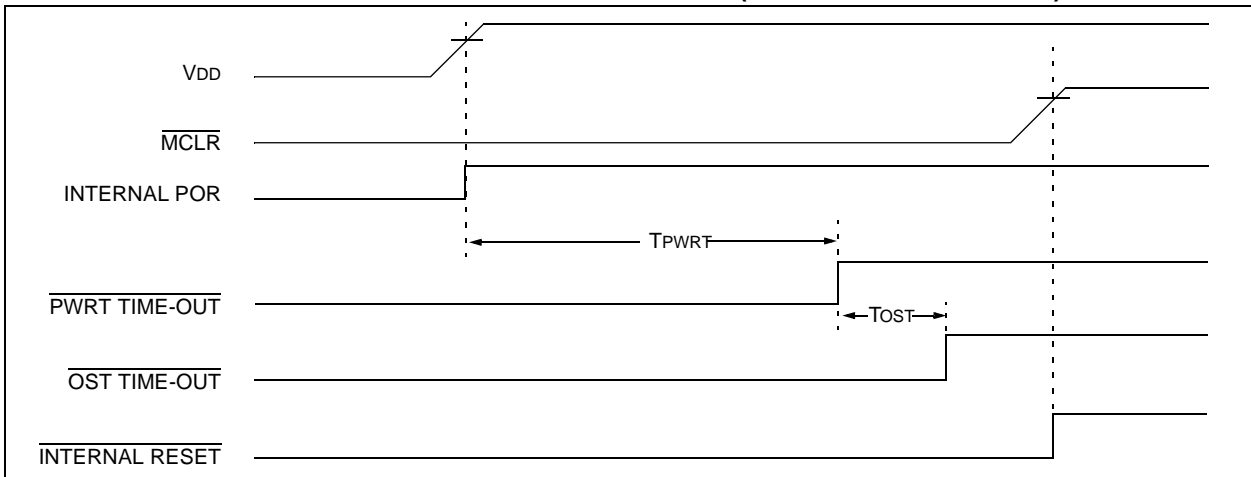
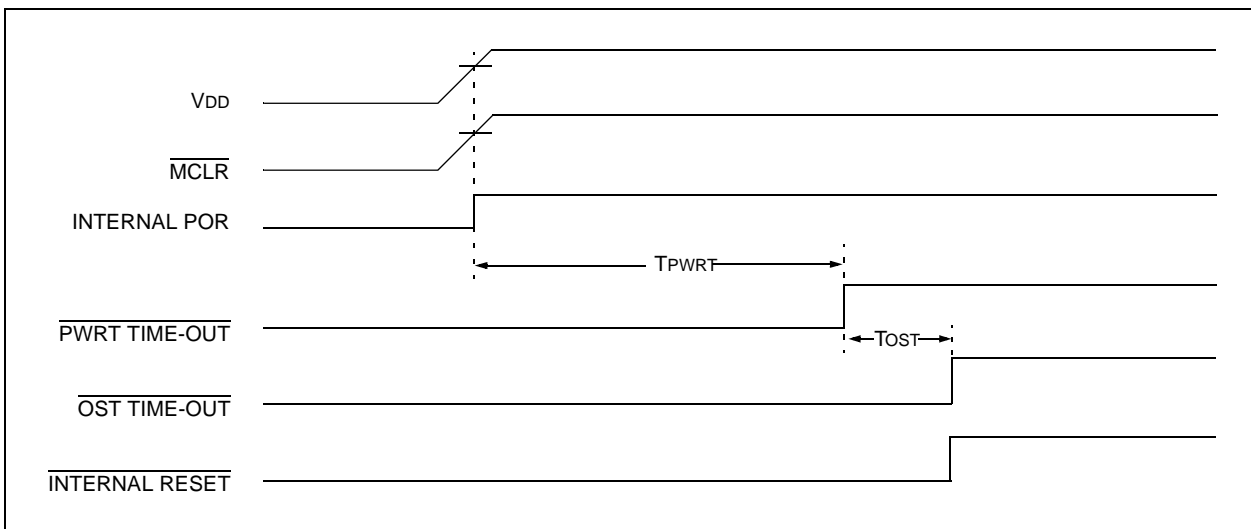
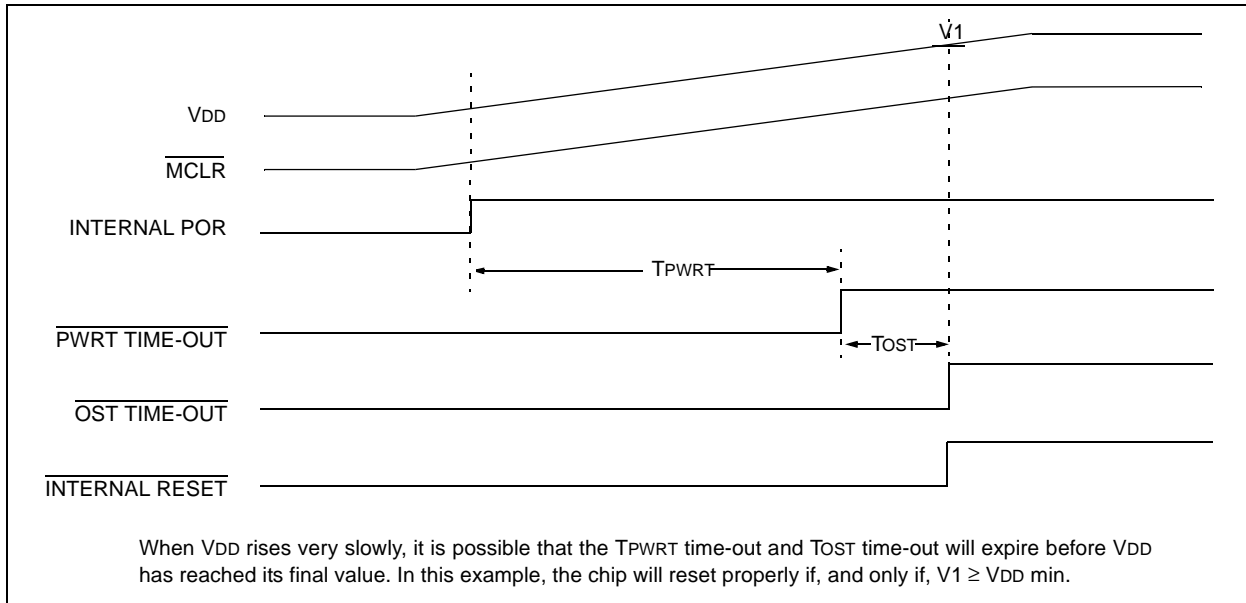

FIGURE 6-8: TIME-OUT SEQUENCE ON POWER-UP ($\overline{\text{MCLR}}$ TIED TO V_{DD}): FAST V_{DD} RISE TIME



PIC16F84A

FIGURE 6-9: TIME-OUT SEQUENCE ON POWER-UP ($\overline{\text{MCLR}}$ TIED TO V_{DD}): SLOW V_{DD} RISE TIME



6.7 Time-out Sequence and Power-down Status Bits ($\overline{\text{TO}}/\overline{\text{PD}}$)

On power-up (Figures 6-6 through 6-9), the time-out sequence is as follows:

1. PWRT time-out is invoked after a POR has expired.
2. Then, the OST is activated.

The total time-out will vary based on oscillator configuration and PWRT configuration bit status. For example, in RC mode with the PWRT disabled, there will be no time-out at all.

TABLE 6-5: TIME-OUT IN VARIOUS SITUATIONS

Oscillator Configuration	Power-up		Wake-up from SLEEP
	PWRT Enabled	PWRT Disabled	
XT, HS, LP	72 ms + $1024T_{\text{osc}}$	$1024T_{\text{osc}}$	$1024T_{\text{osc}}$
RC	72 ms	—	—

Since the time-outs occur from the POR pulse, if $\overline{\text{MCLR}}$ is kept low long enough, the time-outs will expire. Then bringing $\overline{\text{MCLR}}$ high, execution will begin immediately (Figure 6-6). This is useful for testing purposes or to synchronize more than one PIC16F84A device when operating in parallel.

Table 6-6 shows the significance of the $\overline{\text{TO}}$ and $\overline{\text{PD}}$ bits. Table 6-3 lists the RESET conditions for some special registers, while Table 6-4 lists the RESET conditions for all the registers.

TABLE 6-6: STATUS BITS AND THEIR SIGNIFICANCE

$\overline{\text{TO}}$	$\overline{\text{PD}}$	Condition
1	1	Power-on Reset
0	x	Illegal, $\overline{\text{TO}}$ is set on $\overline{\text{POR}}$
x	0	Illegal, $\overline{\text{PD}}$ is set on POR
0	1	WDT Reset (during normal operation)
0	0	WDT Wake-up
1	1	$\overline{\text{MCLR}}$ during normal operation
1	0	$\overline{\text{MCLR}}$ during SLEEP or interrupt wake-up from SLEEP

6.8 Interrupts

The PIC16F84A has 4 sources of interrupt:

- External interrupt RB0/INT pin
- TMR0 overflow interrupt
- PORTB change interrupts (pins RB7:RB4)
- Data EEPROM write complete interrupt

The interrupt control register (INTCON) records individual interrupt requests in flag bits. It also contains the individual and global interrupt enable bits.

The global interrupt enable bit, GIE (INTCON<7>), enables (if set) all unmasked interrupts or disables (if cleared) all interrupts. Individual interrupts can be disabled through their corresponding enable bits in INTCON register. Bit GIE is cleared on RESET.

The “return from interrupt” instruction, *RETFIE*, exits interrupt routine as well as sets the GIE bit, which re-enables interrupts.

The RB0/INT pin interrupt, the RB port change interrupt and the TMR0 overflow interrupt flags are contained in the INTCON register.

When an interrupt is responded to, the GIE bit is cleared to disable any further interrupt, the return address is pushed onto the stack and the PC is loaded with 0004h. For external interrupt events, such as the RB0/INT pin or PORTB change interrupt, the interrupt latency will be three to four instruction cycles. The exact latency depends when the interrupt event occurs. The latency is the same for both one and two cycle instructions. Once in the Interrupt Service Routine, the source(s) of the interrupt can be determined by polling the interrupt flag bits. The interrupt flag bit(s) must be cleared in software before re-enabling interrupts to avoid infinite interrupt requests.

Note: Individual interrupt flag bits are set regardless of the status of their corresponding mask bit or the GIE bit.

6.8.1 INT INTERRUPT

External interrupt on RB0/INT pin is edge triggered: either rising if INTEDG bit (OPTION_REG<6>) is set, or falling if INTEDG bit is clear. When a valid edge appears on the RB0/INT pin, the INTF bit (INTCON<1>) is set. This interrupt can be disabled by clearing control bit INTE (INTCON<4>). Flag bit INTF must be cleared in software via the Interrupt Service Routine before re-enabling this interrupt. The INT interrupt can wake the processor from SLEEP (Section 6.11) only if the INTE bit was set prior to going into SLEEP. The status of the GIE bit decides whether the processor branches to the interrupt vector following wake-up.

6.8.2 TMR0 INTERRUPT

An overflow (FFh → 00h) in TMR0 will set flag bit T0IF (INTCON<2>). The interrupt can be enabled/disabled by setting/clearing enable bit T0IE (INTCON<5>) (Section 5.0).

6.8.3 PORTB INTERRUPT

An input change on PORTB<7:4> sets flag bit RBIF (INTCON<0>). The interrupt can be enabled/disabled by setting/clearing enable bit RBIE (INTCON<3>) (Section 4.2).

Note: For a change on the I/O pin to be recognized, the pulse width must be at least T_{CY} wide.

6.8.4 DATA EEPROM INTERRUPT

At the completion of a data EEPROM write cycle, flag bit EEIF (EECON1<4>) will be set. The interrupt can be enabled/disabled by setting/clearing enable bit EEIE (INTCON<6>) (Section 3.0).

FIGURE 6-10: INTERRUPT LOGIC

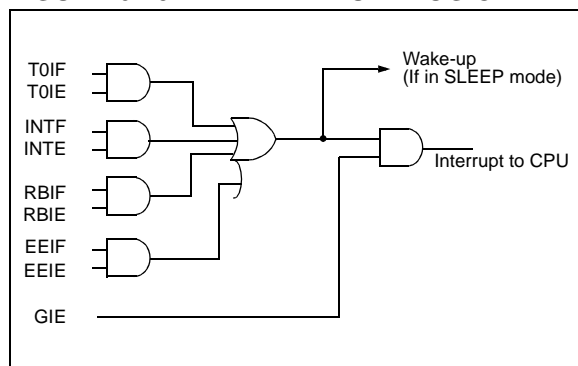

PIC16F84A

6.9 Context Saving During Interrupts

During an interrupt, only the return PC value is saved on the stack. Typically, users wish to save key register values during an interrupt (e.g., W register and STATUS register). This is implemented in software.

The code in Example 6-1 stores and restores the STATUS and W register's values. The user defined registers, W_TEMP and STATUS_TEMP are the temporary storage locations for the W and STATUS registers values.

Example 6-1 does the following:

- a) Stores the W register.
- b) Stores the STATUS register in STATUS_TEMP.
- c) Executes the Interrupt Service Routine code.
- d) Restores the STATUS (and bank select bit) register.
- e) Restores the W register.

EXAMPLE 6-1: SAVING STATUS AND W REGISTERS IN RAM

```
PUSH  MOVWF  W_TEMP      ; Copy W to TEMP register,
      SWAPF  STATUS,    W      ; Swap status to be saved into W
      MOVWF  STATUS_TEMP   ; Save status to STATUS_TEMP register
ISR   :
      :
      :           ; Interrupt Service Routine
      :           ; should configure Bank as required
      :
POP   SWAPF  STATUS_TEMP,W   ; Swap nibbles in STATUS_TEMP register
      :           ; and place result into W
      MOVWF  STATUS        ; Move W into STATUS register
      :           ; (sets bank to original state)
      SWAPF  W_TEMP,     F      ; Swap nibbles in W_TEMP and place result in W_TEMP
      SWAPF  W_TEMP,     W      ; Swap nibbles in W_TEMP and place result into W
```

6.10 Watchdog Timer (WDT)

The Watchdog Timer is a free running On-Chip RC Oscillator which does not require any external components. This RC oscillator is separate from the RC oscillator of the OSC1/CLKIN pin. That means that the WDT will run even if the clock on the OSC1/CLKIN and OSC2/CLKOUT pins of the device has been stopped, for example, by execution of a SLEEP instruction. During normal operation, a WDT time-out generates a device RESET. If the device is in SLEEP mode, a WDT wake-up causes the device to wake-up and continue with normal operation. The WDT can be permanently disabled by programming configuration bit WDTE as a '0' (Section 6.1).

6.10.1 WDT PERIOD

The WDT has a nominal time-out period of 18 ms, (with no prescaler). The time-out periods vary with temperature, VDD and process variations from part to part (see DC specs). If longer time-out periods are desired, a prescaler with a division ratio of up to 1:128 can be assigned to the WDT under software control by writing to the OPTION_REG register. Thus, time-out periods up to 2.3 seconds can be realized.

The CLRWDT and SLEEP instructions clear the WDT and the postscaler (if assigned to the WDT) and prevent it from timing out and generating a device RESET condition.

The \overline{TO} bit in the STATUS register will be cleared upon a WDT time-out.

6.10.2 WDT PROGRAMMING CONSIDERATIONS

It should also be taken into account that under worst case conditions ($V_{DD} = \text{Min.}$, Temperature = Max., Max. WDT Prescaler), it may take several seconds before a WDT time-out occurs.

FIGURE 6-11: WATCHDOG TIMER BLOCK DIAGRAM

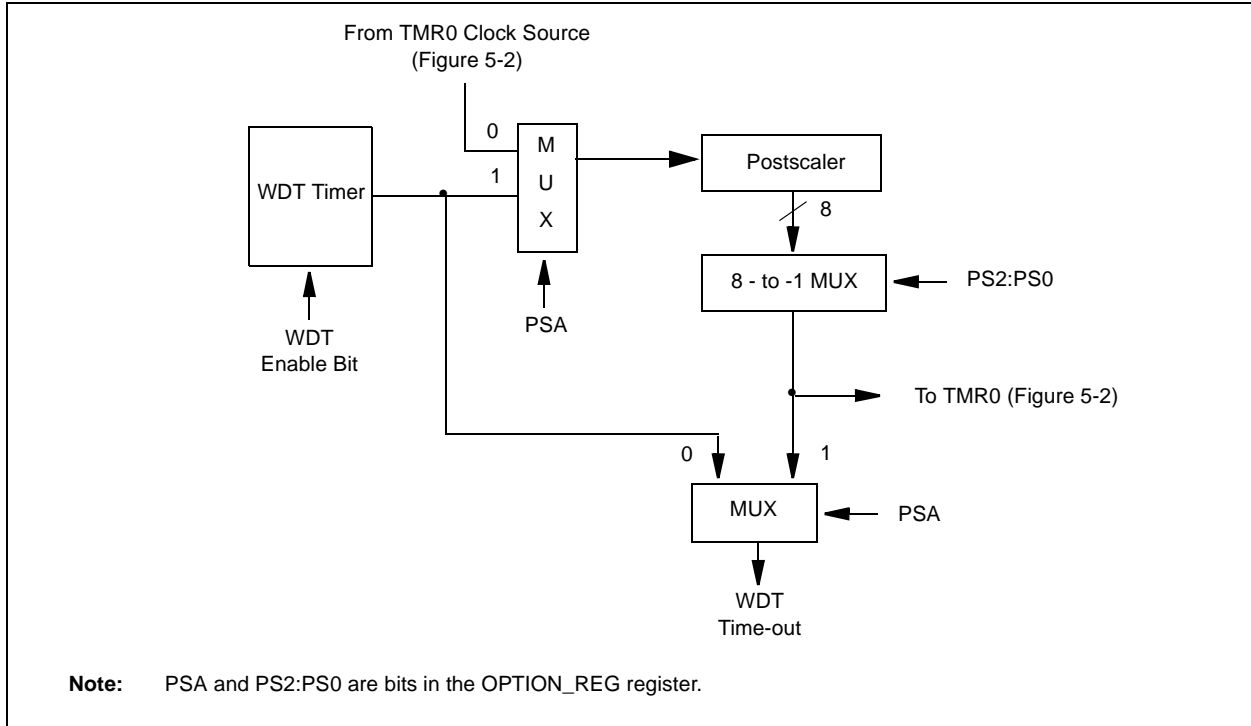

TABLE 6-7: SUMMARY OF REGISTERS ASSOCIATED WITH THE WATCHDOG TIMER

Addr	Name	Bit 7	Bit 6	Bit 5	Bit 4	Bit 3	Bit 2	Bit 1	Bit 0	Value on Power-on Reset	Value on all other RESETS
2007h	Config. bits	(2)	(2)	(2)	(2)	PWRTE ⁽¹⁾	WDTE	FOSC1	FOSC0	(2)	
81h	OPTION_REG	RBPU	INTEDG	T0CS	T0SE	PSA	PS2	PS1	PS0	1111 1111	1111 1111

Legend: x = unknown. Shaded cells are not used by the WDT.

Note 1: See Register 6-1 for operation of the PWRTE bit.

Note 2: See Register 6-1 and Section 6.12 for operation of the code and data protection bits.

PIC16F84A

6.11 Power-down Mode (SLEEP)

A device may be powered down (SLEEP) and later powered up (wake-up from SLEEP).

6.11.1 SLEEP

The Power-down mode is entered by executing the SLEEP instruction.

If enabled, the Watchdog Timer is cleared (but keeps running), the PD bit (STATUS<3>) is cleared, the TO bit (STATUS<4>) is set, and the oscillator driver is turned off. The I/O ports maintain the status they had before the SLEEP instruction was executed (driving high, low, or hi-impedance).

For the lowest current consumption in SLEEP mode, place all I/O pins at either VDD or VSS, with no external circuitry drawing current from the I/O pins, and disable external clocks. I/O pins that are hi-impedance inputs should be pulled high or low externally to avoid switching currents caused by floating inputs. The TOCKI input should also be at VDD or VSS. The contribution from on-chip pull-ups on PORTB should be considered.

The MCLR pin must be at a logic high level (VIHMC).

It should be noted that a RESET generated by a WDT time-out does not drive the MCLR pin low.

6.11.2 WAKE-UP FROM SLEEP

The device can wake-up from SLEEP through one of the following events:

1. External RESET input on MCLR pin.
2. WDT wake-up (if WDT was enabled).
3. Interrupt from RB0/INT pin, RB port change, or data EEPROM write complete.

Peripherals cannot generate interrupts during SLEEP, since no on-chip Q clocks are present.

The first event (MCLR Reset) will cause a device RESET. The two latter events are considered a continuation of program execution. The TO and PD bits can be used to determine the cause of a device RESET. The PD bit, which is set on power-up, is cleared when SLEEP is invoked. The TO bit is cleared if a WDT time-out occurred (and caused wake-up).

While the SLEEP instruction is being executed, the next instruction (PC + 1) is pre-fetched. For the device to wake-up through an interrupt event, the corresponding interrupt enable bit must be set (enabled). Wake-up occurs regardless of the state of the GIE bit. If the GIE bit is clear (disabled), the device continues execution at the instruction after the SLEEP instruction. If the GIE bit is set (enabled), the device executes the instruction after the SLEEP instruction and then branches to the interrupt address (0004h). In cases where the execution of the instruction following SLEEP is not desirable, the user should have a NOP after the SLEEP instruction.

FIGURE 6-12: WAKE-UP FROM SLEEP THROUGH INTERRUPT

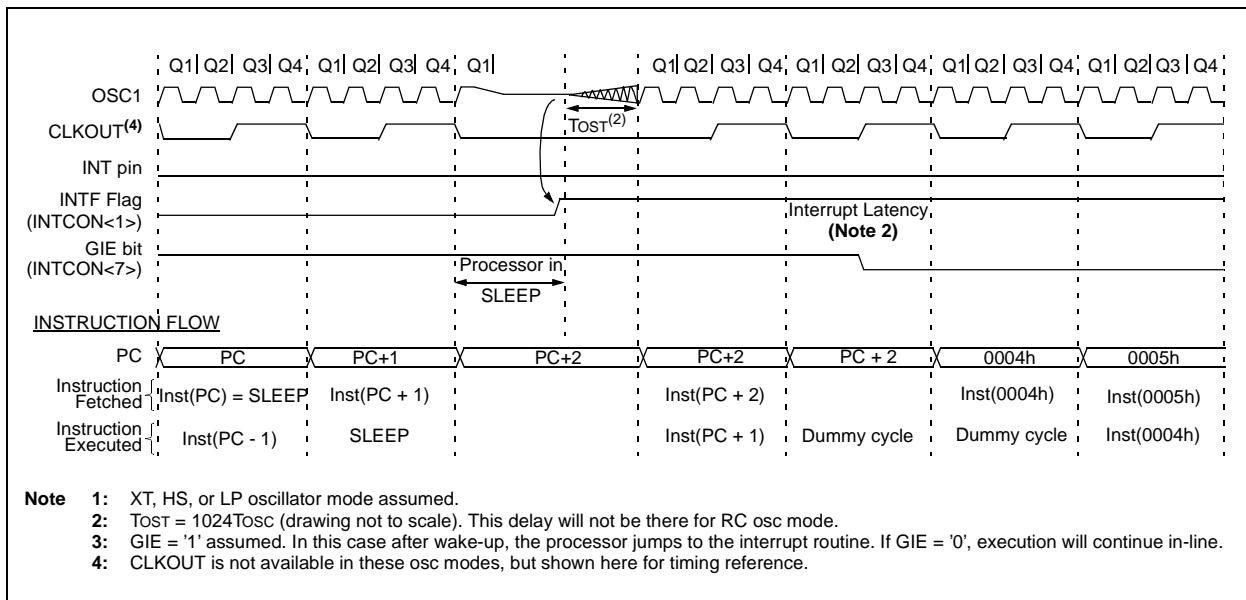

6.11.3 WAKE-UP USING INTERRUPTS

When global interrupts are disabled (GIE cleared) and any interrupt source has both its interrupt enable bit and interrupt flag bit set, one of the following will occur:

- If the interrupt occurs **before** the execution of a `SLEEP` instruction, the `SLEEP` instruction will complete as a `NOP`. Therefore, the `WDT` and `WDT` postscaler will not be cleared, the \overline{TO} bit will not be set and \overline{PD} bits will not be cleared.
- If the interrupt occurs **during or after** the execution of a `SLEEP` instruction, the device will immediately wake-up from `SLEEP`. The `SLEEP` instruction will be completely executed before the wake-up. Therefore, the `WDT` and `WDT` postscaler will be cleared, the \overline{TO} bit will be set and the \overline{PD} bit will be cleared.

Even if the flag bits were checked before executing a `SLEEP` instruction, it may be possible for flag bits to become set before the `SLEEP` instruction completes. To determine whether a `SLEEP` instruction executed, test the \overline{PD} bit. If the \overline{PD} bit is set, the `SLEEP` instruction was executed as a `NOP`.

To ensure that the `WDT` is cleared, a `CLRWDT` instruction should be executed before a `SLEEP` instruction.

6.12 Program Verification/Code Protection

If the code protection bit(s) have not been programmed, the on-chip program memory can be read out for verification purposes.

6.13 ID Locations

Four memory locations (2000h - 2004h) are designated as ID locations to store checksum or other code identification numbers. These locations are not accessible during normal execution but are readable and writable only during program/verify. Only the four Least Significant bits of ID location are usable.

6.14 In-Circuit Serial Programming

PIC16F84A microcontrollers can be serially programmed while in the end application circuit. This is simply done with two lines for clock and data, and three other lines for power, ground, and the programming voltage. Customers can manufacture boards with unprogrammed devices, and then program the microcontroller just before shipping the product, allowing the most recent firmware or custom firmware to be programmed.

For complete details of Serial Programming, please refer to the In-Circuit Serial Programming™ (ICSP™) Guide, (DS30277).

PIC16F84A

NOTES:

7.0 INSTRUCTION SET SUMMARY

Each PIC16CXX instruction is a 14-bit word, divided into an OPCODE which specifies the instruction type and one or more operands which further specify the operation of the instruction. The PIC16CXX instruction set summary in Table 7-2 lists **byte-oriented**, **bit-oriented**, and **literal and control** operations. Table 7-1 shows the opcode field descriptions.

For **byte-oriented** instructions, 'f' represents a file register designator and 'd' represents a destination designator. The file register designator specifies which file register is to be used by the instruction.

The destination designator specifies where the result of the operation is to be placed. If 'd' is zero, the result is placed in the W register. If 'd' is one, the result is placed in the file register specified in the instruction.

For **bit-oriented** instructions, 'b' represents a bit field designator which selects the number of the bit affected by the operation, while 'f' represents the address of the file in which the bit is located.

For **literal and control** operations, 'k' represents an eight or eleven bit constant or literal value.

TABLE 7-1: OPCODE FIELD DESCRIPTIONS

Field	Description
f	Register file address (0x00 to 0x7F)
W	Working register (accumulator)
b	Bit address within an 8-bit file register
k	Literal field, constant data or label
x	Don't care location (= 0 or 1) The assembler will generate code with x = 0. It is the recommended form of use for compatibility with all Microchip software tools.
d	Destination select; d = 0: store result in W, d = 1: store result in file register f. Default is d = 1
PC	Program Counter
TO	Time-out bit
PD	Power-down bit

The instruction set is highly orthogonal and is grouped into three basic categories:

- **Byte-oriented** operations
- **Bit-oriented** operations
- **Literal and control** operations

All instructions are executed within one single instruction cycle, unless a conditional test is true or the program counter is changed as a result of an instruction. In this case, the execution takes two instruction cycles with the second cycle executed as a NOP. One instruction cycle consists of four oscillator periods. Thus, for an oscillator frequency of 4 MHz, the normal instruction execution time is 1 μs. If a conditional test is true or the program counter is changed as a result of an instruction, the instruction execution time is 2 μs.

Table 7-2 lists the instructions recognized by the MPASM™ Assembler.

Figure 7-1 shows the general formats that the instructions can have.

Note: To maintain upward compatibility with future PIC16CXX products, do not use the OPTION and TRIS instructions.

All examples use the following format to represent a hexadecimal number:

0xhh

where h signifies a hexadecimal digit.

FIGURE 7-1: GENERAL FORMAT FOR INSTRUCTIONS

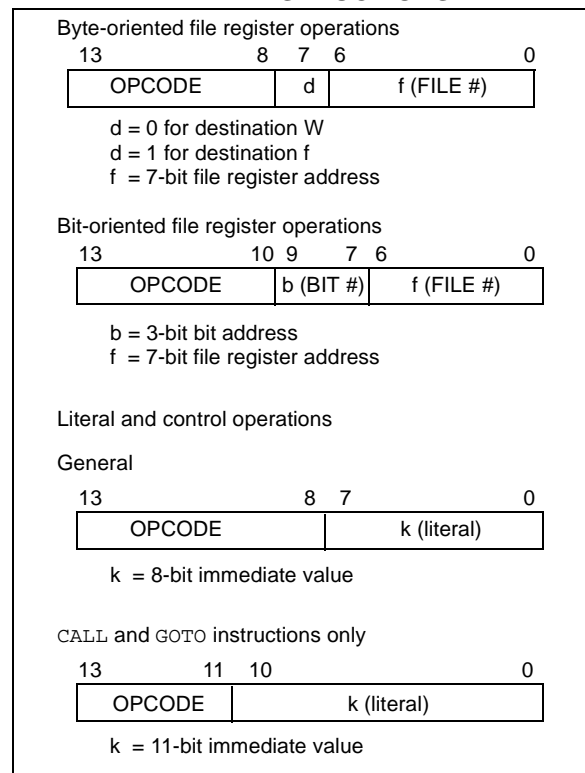

A description of each instruction is available in the PICmicro™ Mid-Range Reference Manual (DS33023).

PIC16F84A

TABLE 7-2: PIC16CXXX INSTRUCTION SET

Mnemonic, Operands	Description	Cycles	14-Bit Opcode				Status Affected	Notes	
			MSb	LSb					
BYTE-ORIENTED FILE REGISTER OPERATIONS									
ADDWF	f, d	Add W and f	1	00	0111	dfff	ffff	C,DC,Z	1,2
ANDWF	f, d	AND W with f	1	00	0101	dfff	ffff	Z	1,2
CLRF	f	Clear f	1	00	0001	1fff	ffff	Z	2
CLRWF	-	Clear W	1	00	0001	0xxx	xxxx	Z	
COMF	f, d	Complement f	1	00	1001	dfff	ffff	Z	1,2
DECf	f, d	Decrement f	1	00	0011	dfff	ffff	Z	1,2
DECFSZ	f, d	Decrement f, Skip if 0	1 (2)	00	1011	dfff	ffff		1,2,3
INCF	f, d	Increment f	1	00	1010	dfff	ffff	Z	1,2
INCFSZ	f, d	Increment f, Skip if 0	1 (2)	00	1111	dfff	ffff		1,2,3
IORWF	f, d	Inclusive OR W with f	1	00	0100	dfff	ffff	Z	1,2
MOVF	f, d	Move f	1	00	1000	dfff	ffff	Z	1,2
MOVWF	f	Move W to f	1	00	0000	1fff	ffff		
NOP	-	No Operation	1	00	0000	0xx0	0000		
RLF	f, d	Rotate Left f through Carry	1	00	1101	dfff	ffff	C	1,2
RRF	f, d	Rotate Right f through Carry	1	00	1100	dfff	ffff	C	1,2
SUBWF	f, d	Subtract W from f	1	00	0010	dfff	ffff	C,DC,Z	1,2
SWAPF	f, d	Swap nibbles in f	1	00	1110	dfff	ffff		1,2
XORWF	f, d	Exclusive OR W with f	1	00	0110	dfff	ffff	Z	1,2
BIT-ORIENTED FILE REGISTER OPERATIONS									
BCF	f, b	Bit Clear f	1	01	00bb	bfff	ffff		1,2
BSF	f, b	Bit Set f	1	01	01bb	bfff	ffff		1,2
BTFSC	f, b	Bit Test f, Skip if Clear	1 (2)	01	10bb	bfff	ffff		3
BTFSS	f, b	Bit Test f, Skip if Set	1 (2)	01	11bb	bfff	ffff		3
LITERAL AND CONTROL OPERATIONS									
ADDLW	k	Add literal and W	1	11	111x	kkkk	kkkk	C,DC,Z	
ANDLW	k	AND literal with W	1	11	1001	kkkk	kkkk	Z	
CALL	k	Call subroutine	2	10	0kkk	kkkk	kkkk		
CLRWDT	-	Clear Watchdog Timer	1	00	0000	0110	0100	$\overline{TO}, \overline{PD}$	
GOTO	k	Go to address	2	10	1kkk	kkkk	kkkk		
IORLW	k	Inclusive OR literal with W	1	11	1000	kkkk	kkkk	Z	
MOVLW	k	Move literal to W	1	11	00xx	kkkk	kkkk		
RETFIE	-	Return from interrupt	2	00	0000	0000	1001		
RETLW	k	Return with literal in W	2	11	01xx	kkkk	kkkk		
RETURN	-	Return from Subroutine	2	00	0000	0000	1000		
SLEEP	-	Go into standby mode	1	00	0000	0110	0011	$\overline{TO}, \overline{PD}$	
SUBLW	k	Subtract W from literal	1	11	110x	kkkk	kkkk	C,DC,Z	
XORLW	k	Exclusive OR literal with W	1	11	1010	kkkk	kkkk	Z	

- Note 1:** When an I/O register is modified as a function of itself (e.g., `MOVWF PORTB, 1`), the value used will be that value present on the pins themselves. For example, if the data latch is '1' for a pin configured as input and is driven low by an external device, the data will be written back with a '0'.
- Note 2:** If this instruction is executed on the TMR0 register (and, where applicable, d = 1), the prescaler will be cleared if assigned to the Timer0 Module.
- Note 3:** If Program Counter (PC) is modified or a conditional test is true, the instruction requires two cycles. The second cycle is executed as a NOP.

Note: Additional information on the mid-range instruction set is available in the PICmicro™ Mid-Range MCU Family Reference Manual (DS33023).

7.1 Instruction Descriptions

ADDLW **Add Literal and W**

Syntax: *[label]* ADDLW *k*
 Operands: $0 \leq k \leq 255$
 Operation: $(W) + k \rightarrow (W)$
 Status Affected: C, DC, Z
 Description: The contents of the W register are added to the eight-bit literal 'k' and the result is placed in the W register.

ADDWF **Add W and f**

Syntax: *[label]* ADDWF *f,d*
 Operands: $0 \leq f \leq 127$
 $d \in [0,1]$
 Operation: $(W) + (f) \rightarrow (\text{destination})$
 Status Affected: C, DC, Z
 Description: Add the contents of the W register with register 'f'. If 'd' is 0, the result is stored in the W register. If 'd' is 1, the result is stored back in register 'f'.

ANDLW **AND Literal with W**

Syntax: *[label]* ANDLW *k*
 Operands: $0 \leq k \leq 255$
 Operation: $(W) \text{ .AND. } (k) \rightarrow (W)$
 Status Affected: Z
 Description: The contents of W register are AND'ed with the eight-bit literal 'k'. The result is placed in the W register.

ANDWF **AND W with f**

Syntax: *[label]* ANDWF *f,d*
 Operands: $0 \leq f \leq 127$
 $d \in [0,1]$
 Operation: $(W) \text{ .AND. } (f) \rightarrow (\text{destination})$
 Status Affected: Z
 Description: AND the W register with register 'f'. If 'd' is 0, the result is stored in the W register. If 'd' is 1, the result is stored back in register 'f'.

BCF **Bit Clear f**

Syntax: *[label]* BCF *f,b*
 Operands: $0 \leq f \leq 127$
 $0 \leq b \leq 7$
 Operation: $0 \rightarrow (f)$
 Status Affected: None
 Description: Bit 'b' in register 'f' is cleared.

BSF **Bit Set f**

Syntax: *[label]* BSF *f,b*
 Operands: $0 \leq f \leq 127$
 $0 \leq b \leq 7$
 Operation: $1 \rightarrow (f)$
 Status Affected: None
 Description: Bit 'b' in register 'f' is set.

BTFSS **Bit Test f, Skip if Set**

Syntax: *[label]* BTFSS *f,b*
 Operands: $0 \leq f \leq 127$
 $0 \leq b < 7$
 Operation: skip if $(f) = 1$
 Status Affected: None
 Description: If bit 'b' in register 'f' is '0', the next instruction is executed.
 If bit 'b' is '1', then the next instruction is discarded and a NOP is executed instead, making this a 2TCY instruction.

PIC16F84A

BTFSC	Bit Test, Skip if Clear
Syntax:	[<i>label</i>] BTFSC f,b
Operands:	$0 \leq f \leq 127$ $0 \leq b \leq 7$
Operation:	skip if (f) = 0
Status Affected:	None
Description:	If bit 'b' in register 'f' is '1', the next instruction is executed. If bit 'b' in register 'f' is '0', the next instruction is discarded, and a NOP is executed instead, making this a 2TCY instruction.

CALL	Call Subroutine
Syntax:	[<i>label</i>] CALL k
Operands:	$0 \leq k \leq 2047$
Operation:	(PC)+1 → TOS, k → PC<10:0>, (PCLATH<4:3>) → PC<12:11>
Status Affected:	None
Description:	Call Subroutine. First, return address (PC+1) is pushed onto the stack. The eleven-bit immediate address is loaded into PC bits <10:0>. The upper bits of the PC are loaded from PCLATH. CALL is a two-cycle instruction.

CLRF	Clear f
Syntax:	[<i>label</i>] CLRF f
Operands:	$0 \leq f \leq 127$
Operation:	00h → (f) 1 → Z
Status Affected:	Z
Description:	The contents of register 'f' are cleared and the Z bit is set.

CLRW	Clear W
Syntax:	[<i>label</i>] CLRW
Operands:	None
Operation:	00h → (W) 1 → Z
Status Affected:	Z
Description:	W register is cleared. Zero bit (Z) is set.

CLRWDT	Clear Watchdog Timer
Syntax:	[<i>label</i>] CLRWDT
Operands:	None
Operation:	00h → WDT 0 → WDT prescaler, 1 → \overline{TO} 1 → \overline{PD}
Status Affected:	\overline{TO} , \overline{PD}
Description:	CLRWDT instruction resets the Watchdog Timer. It also resets the prescaler of the WDT. Status bits \overline{TO} and \overline{PD} are set.

COMF	Complement f
Syntax:	[<i>label</i>] COMF f,d
Operands:	$0 \leq f \leq 127$ d ∈ [0,1]
Operation:	(\bar{f}) → (destination)
Status Affected:	Z
Description:	The contents of register 'f' are complemented. If 'd' is 0, the result is stored in W. If 'd' is 1, the result is stored back in register 'f'.

DECF	Decrement f
Syntax:	[<i>label</i>] DECF f,d
Operands:	$0 \leq f \leq 127$ d ∈ [0,1]
Operation:	(f) - 1 → (destination)
Status Affected:	Z
Description:	Decrement register 'f'. If 'd' is 0, the result is stored in the W register. If 'd' is 1, the result is stored back in register 'f'.

DECFSZ Decrement f, Skip if 0

Syntax: [*label*] DECFSZ f,d

Operands: $0 \leq f \leq 127$
 $d \in [0,1]$

Operation: (f) - 1 → (destination);
 skip if result = 0

Status Affected: None

Description: The contents of register 'f' are decremented. If 'd' is 0, the result is placed in the W register. If 'd' is 1, the result is placed back in register 'f'.
 If the result is 1, the next instruction is executed. If the result is 0, then a NOP is executed instead, making it a 2TCY instruction.

INCFSZ Increment f, Skip if 0

Syntax: [*label*] INCFSZ f,d

Operands: $0 \leq f \leq 127$
 $d \in [0,1]$

Operation: (f) + 1 → (destination),
 skip if result = 0

Status Affected: None

Description: The contents of register 'f' are incremented. If 'd' is 0, the result is placed in the W register. If 'd' is 1, the result is placed back in register 'f'.
 If the result is 1, the next instruction is executed. If the result is 0, a NOP is executed instead, making it a 2TCY instruction.

GOTO Unconditional Branch

Syntax: [*label*] GOTO k

Operands: $0 \leq k \leq 2047$

Operation: $k \rightarrow PC<10:0>$
 $PCLATH<4:3> \rightarrow PC<12:11>$

Status Affected: None

Description: GOTO is an unconditional branch. The eleven-bit immediate value is loaded into PC bits <10:0>. The upper bits of PC are loaded from PCLATH<4:3>. GOTO is a two-cycle instruction.

IORLW Inclusive OR Literal with W

Syntax: [*label*] IORLW k

Operands: $0 \leq k \leq 255$

Operation: (W) .OR. k → (W)

Status Affected: Z

Description: The contents of the W register are OR'ed with the eight-bit literal 'k'. The result is placed in the W register.

INCF Increment f

Syntax: [*label*] INCF f,d

Operands: $0 \leq f \leq 127$
 $d \in [0,1]$

Operation: (f) + 1 → (destination)

Status Affected: Z

Description: The contents of register 'f' are incremented. If 'd' is 0, the result is placed in the W register. If 'd' is 1, the result is placed back in register 'f'.

IORWF Inclusive OR W with f

Syntax: [*label*] IORWF f,d

Operands: $0 \leq f \leq 127$
 $d \in [0,1]$

Operation: (W) .OR. (f) → (destination)

Status Affected: Z

Description: Inclusive OR the W register with register 'f'. If 'd' is 0, the result is placed in the W register. If 'd' is 1, the result is placed back in register 'f'.

PIC16F84A

MOVF **Move f**

Syntax: [*label*] MOVF f,d

Operands: $0 \leq f \leq 127$
 $d \in [0,1]$

Operation: (f) → (destination)

Status Affected: Z

Description: The contents of register f are moved to a destination dependant upon the status of d. If d = 0, destination is W register. If d = 1, the destination is file register f itself. d = 1 is useful to test a file register, since status flag Z is affected.

RETFIE **Return from Interrupt**

Syntax: [*label*] RETFIE

Operands: None

Operation: TOS → PC,
 1 → GIE

Status Affected: None

MOVLW **Move Literal to W**

Syntax: [*label*] MOVLW k

Operands: $0 \leq k \leq 255$

Operation: $k \rightarrow (W)$

Status Affected: None

Description: The eight-bit literal 'k' is loaded into W register. The don't cares will assemble as 0's.

RETLW **Return with Literal in W**

Syntax: [*label*] RETLW k

Operands: $0 \leq k \leq 255$

Operation: $k \rightarrow (W)$;
 TOS → PC

Status Affected: None

Description: The W register is loaded with the eight-bit literal 'k'. The program counter is loaded from the top of the stack (the return address). This is a two-cycle instruction.

MOVWF **Move W to f**

Syntax: [*label*] MOVWF f

Operands: $0 \leq f \leq 127$

Operation: (W) → (f)

Status Affected: None

Description: Move data from W register to register 'f'.

RETURN **Return from Subroutine**

Syntax: [*label*] RETURN

Operands: None

Operation: TOS → PC

Status Affected: None

Description: Return from subroutine. The stack is POPed and the top of the stack (TOS) is loaded into the program counter. This is a two-cycle instruction.

NOP **No Operation**

Syntax: [*label*] NOP

Operands: None

Operation: No operation

Status Affected: None

Description: No operation.

RLF **Rotate Left f through Carry**

Syntax: [*label*] RLF f,d

Operands: $0 \leq f \leq 127$
 $d \in [0,1]$

Operation: See description below

Status Affected: C

Description: The contents of register 'f' are rotated one bit to the left through the Carry Flag. If 'd' is 0, the result is placed in the W register. If 'd' is 1, the result is stored back in register 'f'.

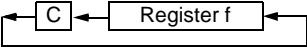

SUBLW **Subtract W from Literal**

Syntax: [*label*] SUBLW k

Operands: $0 \leq k \leq 255$

Operation: $k - (W) \rightarrow (W)$

Status Affected: C, DC, Z

Description: The W register is subtracted (2's complement method) from the eight-bit literal 'k'. The result is placed in the W register.

RRF **Rotate Right f through Carry**

Syntax: [*label*] RRF f,d

Operands: $0 \leq f \leq 127$
 $d \in [0,1]$

Operation: See description below

Status Affected: C

Description: The contents of register 'f' are rotated one bit to the right through the Carry Flag. If 'd' is 0, the result is placed in the W register. If 'd' is 1, the result is placed back in register 'f'.

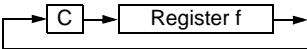

SUBWF **Subtract W from f**

Syntax: [*label*] SUBWF f,d

Operands: $0 \leq f \leq 127$
 $d \in [0,1]$

Operation: $(f) - (W) \rightarrow (\text{destination})$

Status Affected: C, DC, Z

Description: Subtract (2's complement method) W register from register 'f'. If 'd' is 0, the result is stored in the W register. If 'd' is 1, the result is stored back in register 'f'.

SLEEP

Syntax: [*label*] SLEEP

Operands: None

Operation: $00h \rightarrow \text{WDT}$,
 $0 \rightarrow \text{WDT prescaler}$,
 $1 \rightarrow \overline{\text{TO}}$,
 $0 \rightarrow \overline{\text{PD}}$

Status Affected: $\overline{\text{TO}}$, $\overline{\text{PD}}$

Description: The power-down status bit, $\overline{\text{PD}}$ is cleared. Time-out status bit, $\overline{\text{TO}}$ is set. Watchdog Timer and its prescaler are cleared. The processor is put into SLEEP mode with the oscillator stopped.

SWAPF **Swap Nibbles in f**

Syntax: [*label*] SWAPF f,d

Operands: $0 \leq f \leq 127$
 $d \in [0,1]$

Operation: $(f<3:0>) \rightarrow (\text{destination}<7:4>)$,
 $(f<7:4>) \rightarrow (\text{destination}<3:0>)$

Status Affected: None

Description: The upper and lower nibbles of register 'f' are exchanged. If 'd' is 0, the result is placed in W register. If 'd' is 1, the result is placed in register 'f'.

PIC16F84A

XORLW **Exclusive OR Literal with W**

Syntax: *[label]* XORLW k
Operands: $0 \leq k \leq 255$
Operation: (W) .XOR. k \rightarrow (W)
Status Affected: Z
Description: The contents of the W register are XOR'ed with the eight-bit literal 'k'. The result is placed in the W register.

XORWF **Exclusive OR W with f**

Syntax: *[label]* XORWF f,d
Operands: $0 \leq f \leq 127$
 $d \in [0,1]$
Operation: (W) .XOR. (f) \rightarrow (destination)
Status Affected: Z
Description: Exclusive OR the contents of the W register with register 'f'. If 'd' is 0, the result is stored in the W register. If 'd' is 1, the result is stored back in register 'f'.

8.0 DEVELOPMENT SUPPORT

The PICmicro[®] microcontrollers are supported with a full range of hardware and software development tools:

- Integrated Development Environment
 - MPLAB[®] IDE Software
- Assemblers/Compilers/Linkers
 - MPASM[™] Assembler
 - MPLAB C17 and MPLAB C18 C Compilers
 - MPLINK[™] Object Linker/
MPLIB[™] Object Librarian
- Simulators
 - MPLAB SIM Software Simulator
- Emulators
 - MPLAB ICE 2000 In-Circuit Emulator
 - ICEPIC[™] In-Circuit Emulator
- In-Circuit Debugger
 - MPLAB ICD
- Device Programmers
 - PRO MATE[®] II Universal Device Programmer
 - PICSTART[®] Plus Entry-Level Development Programmer
- Low Cost Demonstration Boards
 - PICDEM[™] 1 Demonstration Board
 - PICDEM 2 Demonstration Board
 - PICDEM 3 Demonstration Board
 - PICDEM 17 Demonstration Board
 - KEELOQ[®] Demonstration Board

8.1 MPLAB Integrated Development Environment Software

The MPLAB IDE software brings an ease of software development previously unseen in the 8-bit microcontroller market. The MPLAB IDE is a Windows[®]-based application that contains:

- An interface to debugging tools
 - simulator
 - programmer (sold separately)
 - emulator (sold separately)
 - in-circuit debugger (sold separately)
- A full-featured editor
- A project manager
- Customizable toolbar and key mapping
- A status bar
- On-line help

The MPLAB IDE allows you to:

- Edit your source files (either assembly or 'C')
- One touch assemble (or compile) and download to PICmicro emulator and simulator tools (automatically updates all project information)
- Debug using:
 - source files
 - absolute listing file
 - machine code

The ability to use MPLAB IDE with multiple debugging tools allows users to easily switch from the cost-effective simulator to a full-featured emulator with minimal retraining.

8.2 MPASM Assembler

The MPASM assembler is a full-featured universal macro assembler for all PICmicro MCU's.

The MPASM assembler has a command line interface and a Windows shell. It can be used as a stand-alone application on a Windows 3.x or greater system, or it can be used through MPLAB IDE. The MPASM assembler generates relocatable object files for the MPLINK object linker, Intel[®] standard HEX files, MAP files to detail memory usage and symbol reference, an absolute LST file that contains source lines and generated machine code, and a COD file for debugging.

The MPASM assembler features include:

- Integration into MPLAB IDE projects.
- User-defined macros to streamline assembly code.
- Conditional assembly for multi-purpose source files.
- Directives that allow complete control over the assembly process.

8.3 MPLAB C17 and MPLAB C18 C Compilers

The MPLAB C17 and MPLAB C18 Code Development Systems are complete ANSI 'C' compilers for Microchip's PIC17CXXX and PIC18CXXX family of microcontrollers, respectively. These compilers provide powerful integration capabilities and ease of use not found with other compilers.

For easier source level debugging, the compilers provide symbol information that is compatible with the MPLAB IDE memory display.

8.4 MPLINK Object Linker/ MPLIB Object Librarian

The MPLINK object linker combines relocatable objects created by the MPASM assembler and the MPLAB C17 and MPLAB C18 C compilers. It can also link relocatable objects from pre-compiled libraries, using directives from a linker script.

The MPLIB object librarian is a librarian for pre-compiled code to be used with the MPLINK object linker. When a routine from a library is called from another source file, only the modules that contain that routine will be linked in with the application. This allows large libraries to be used efficiently in many different applications. The MPLIB object librarian manages the creation and modification of library files.

The MPLINK object linker features include:

- Integration with MPASM assembler and MPLAB C17 and MPLAB C18 C compilers.
- Allows all memory areas to be defined as sections to provide link-time flexibility.

The MPLIB object librarian features include:

- Easier linking because single libraries can be included instead of many smaller files.
- Helps keep code maintainable by grouping related modules together.
- Allows libraries to be created and modules to be added, listed, replaced, deleted or extracted.

8.5 MPLAB SIM Software Simulator

The MPLAB SIM software simulator allows code development in a PC-hosted environment by simulating the PICmicro series microcontrollers on an instruction level. On any given instruction, the data areas can be examined or modified and stimuli can be applied from a file, or user-defined key press, to any of the pins. The execution can be performed in single step, execute until break, or trace mode.

The MPLAB SIM simulator fully supports symbolic debugging using the MPLAB C17 and the MPLAB C18 C compilers and the MPASM assembler. The software simulator offers the flexibility to develop and debug code outside of the laboratory environment, making it an excellent multi-project software development tool.

8.6 MPLAB ICE High Performance Universal In-Circuit Emulator with MPLAB IDE

The MPLAB ICE universal in-circuit emulator is intended to provide the product development engineer with a complete microcontroller design tool set for PICmicro microcontrollers (MCUs). Software control of the MPLAB ICE in-circuit emulator is provided by the MPLAB Integrated Development Environment (IDE), which allows editing, building, downloading and source debugging from a single environment.

The MPLAB ICE 2000 is a full-featured emulator system with enhanced trace, trigger and data monitoring features. Interchangeable processor modules allow the system to be easily reconfigured for emulation of different processors. The universal architecture of the MPLAB ICE in-circuit emulator allows expansion to support new PICmicro microcontrollers.

The MPLAB ICE in-circuit emulator system has been designed as a real-time emulation system, with advanced features that are generally found on more expensive development tools. The PC platform and Microsoft® Windows® environment were chosen to best make these features available to you, the end user.

8.7 ICEPIC In-Circuit Emulator

The ICEPIC low cost, in-circuit emulator is a solution for the Microchip Technology PIC16C5X, PIC16C6X, PIC16C7X and PIC16CXXX families of 8-bit One-Time-Programmable (OTP) microcontrollers. The modular system can support different subsets of PIC16C5X or PIC16CXXX products through the use of interchangeable personality modules, or daughter boards. The emulator is capable of emulating without target application circuitry being present.

8.8 MPLAB ICD In-Circuit Debugger

Microchip's In-Circuit Debugger, MPLAB ICD, is a powerful, low cost, run-time development tool. This tool is based on the FLASH PICmicro MCUs and can be used to develop for this and other PICmicro microcontrollers. The MPLAB ICD utilizes the in-circuit debugging capability built into the FLASH devices. This feature, along with Microchip's In-Circuit Serial Programming™ protocol, offers cost-effective in-circuit FLASH debugging from the graphical user interface of the MPLAB Integrated Development Environment. This enables a designer to develop and debug source code by watching variables, single-stepping and setting break points. Running at full speed enables testing hardware in real-time.

8.9 PRO MATE II Universal Device Programmer

The PRO MATE II universal device programmer is a full-featured programmer, capable of operating in stand-alone mode, as well as PC-hosted mode. The PRO MATE II device programmer is CE compliant.

The PRO MATE II device programmer has programmable VDD and VPP supplies, which allow it to verify programmed memory at VDD min and VDD max for maximum reliability. It has an LCD display for instructions and error messages, keys to enter commands and a modular detachable socket assembly to support various package types. In stand-alone mode, the PRO MATE II device programmer can read, verify, or program PICmicro devices. It can also set code protection in this mode.

8.10 PICSTART Plus Entry Level Development Programmer

The PICSTART Plus development programmer is an easy-to-use, low cost, prototype programmer. It connects to the PC via a COM (RS-232) port. MPLAB Integrated Development Environment software makes using the programmer simple and efficient.

The PICSTART Plus development programmer supports all PICmicro devices with up to 40 pins. Larger pin count devices, such as the PIC16C92X and PIC17C76X, may be supported with an adapter socket. The PICSTART Plus development programmer is CE compliant.

8.11 PICDEM 1 Low Cost PICmicro Demonstration Board

The PICDEM 1 demonstration board is a simple board which demonstrates the capabilities of several of Microchip's microcontrollers. The microcontrollers supported are: PIC16C5X (PIC16C54 to PIC16C58A), PIC16C61, PIC16C62X, PIC16C71, PIC16C8X, PIC17C42, PIC17C43 and PIC17C44. All necessary hardware and software is included to run basic demo programs. The user can program the sample microcontrollers provided with the PICDEM 1 demonstration board on a PRO MATE II device programmer, or a PICSTART Plus development programmer, and easily test firmware. The user can also connect the PICDEM 1 demonstration board to the MPLAB ICE in-circuit emulator and download the firmware to the emulator for testing. A prototype area is available for the user to build some additional hardware and connect it to the microcontroller socket(s). Some of the features include an RS-232 interface, a potentiometer for simulated analog input, push button switches and eight LEDs connected to PORTB.

8.12 PICDEM 2 Low Cost PIC16CXX Demonstration Board

The PICDEM 2 demonstration board is a simple demonstration board that supports the PIC16C62, PIC16C64, PIC16C65, PIC16C73 and PIC16C74 microcontrollers. All the necessary hardware and software is included to run the basic demonstration programs. The user can program the sample microcontrollers provided with the PICDEM 2 demonstration board on a PRO MATE II device programmer, or a PICSTART Plus development programmer, and easily test firmware. The MPLAB ICE in-circuit emulator may also be used with the PICDEM 2 demonstration board to test firmware. A prototype area has been provided to the user for adding additional hardware and connecting it to the microcontroller socket(s). Some of the features include a RS-232 interface, push button switches, a potentiometer for simulated analog input, a serial EEPROM to demonstrate usage of the I2CTM bus and separate headers for connection to an LCD module and a keypad.

PIC16F84A

8.13 PICDEM 3 Low Cost PIC16CXXX Demonstration Board

The PICDEM 3 demonstration board is a simple demonstration board that supports the PIC16C923 and PIC16C924 in the PLCC package. It will also support future 44-pin PLCC microcontrollers with an LCD Module. All the necessary hardware and software is included to run the basic demonstration programs. The user can program the sample microcontrollers provided with the PICDEM 3 demonstration board on a PRO MATE II device programmer, or a PICSTART Plus development programmer with an adapter socket, and easily test firmware. The MPLAB ICE in-circuit emulator may also be used with the PICDEM 3 demonstration board to test firmware. A prototype area has been provided to the user for adding hardware and connecting it to the microcontroller socket(s). Some of the features include a RS-232 interface, push button switches, a potentiometer for simulated analog input, a thermistor and separate headers for connection to an external LCD module and a keypad. Also provided on the PICDEM 3 demonstration board is a LCD panel, with 4 commons and 12 segments, that is capable of displaying time, temperature and day of the week. The PICDEM 3 demonstration board provides an additional RS-232 interface and Windows software for showing the demultiplexed LCD signals on a PC. A simple serial interface allows the user to construct a hardware demultiplexer for the LCD signals.

8.14 PICDEM 17 Demonstration Board

The PICDEM 17 demonstration board is an evaluation board that demonstrates the capabilities of several Microchip microcontrollers, including PIC17C752, PIC17C756A, PIC17C762 and PIC17C766. All necessary hardware is included to run basic demo programs, which are supplied on a 3.5-inch disk. A programmed sample is included and the user may erase it and program it with the other sample programs using the PRO MATE II device programmer, or the PICSTART Plus development programmer, and easily debug and test the sample code. In addition, the PICDEM 17 demonstration board supports downloading of programs to and executing out of external FLASH memory on board. The PICDEM 17 demonstration board is also usable with the MPLAB ICE in-circuit emulator, or the PICMASTER emulator and all of the sample programs can be run and modified using either emulator. Additionally, a generous prototype area is available for user hardware.

8.15 KEELOQ Evaluation and Programming Tools

KEELOQ evaluation and programming tools support Microchip's HCS Secure Data Products. The HCS evaluation kit includes a LCD display to show changing codes, a decoder to decode transmissions and a programming interface to program test transmitters.

TABLE 8-1: DEVELOPMENT TOOLS FROM MICROCHIP

Tool	PIC12CXXXX	PIC14000	PIC16C5X	PIC16C6X	PIC16CXX	PIC16C7X	PIC16C7XX	PIC16C8X	PIC16F8XX	PIC16C9XX	PIC17C4X	PIC17C7XX	PIC18CXX2	PIC18FXX	24CXX/ 25CXX/ 93CXX	HCSXX	MCRFXXX	MCP2510
Software Tools																		
MPLAB® Integrated Development Environment	✓	✓	✓	✓	✓	✓	✓	✓	✓	✓	✓	✓	✓	✓	✓	✓	✓	✓
MPLAB® C17 C Compiler																		
MPLAB® C18 C Compiler																		
MPASM™ Assembler/ MPLINK™ Object Linker	✓	✓	✓	✓	✓	✓	✓	✓	✓	✓	✓	✓	✓	✓	✓	✓	✓	✓
MPLAB® ICE In-Circuit Emulator	✓	✓	✓	✓	✓	✓	✓	✓	✓	✓	✓	✓	✓	✓	✓	✓	✓	✓
ICEPIC™ In-Circuit Emulator	✓		✓	✓	✓	✓	✓	✓	✓	✓	✓	✓	✓	✓	✓	✓	✓	✓
Debugger																		
MPLAB® ICD In-Circuit Debugger				✓*		✓*			✓					✓				
Programmers																		
PICSTART® Plus Entry Level Development Programmer	✓	✓	✓	✓	✓	✓	✓	✓	✓	✓	✓	✓	✓	✓	✓	✓	✓	✓
PRO MATE® II Universal Device Programmer	✓	✓	✓	✓	✓	✓	✓	✓	✓	✓	✓	✓	✓	✓	✓	✓	✓	✓
Demo Boards and Eval Kits																		
PICDEM™ 1 Demonstration Board			✓		✓			✓			✓							
PICDEM™ 2 Demonstration Board				✓†									✓					
PICDEM™ 3 Demonstration Board									✓									
PICDEM™ 14A Demonstration Board		✓																
PICDEM™ 17 Demonstration Board											✓							
KEELOQ® Evaluation Kit																✓		
KEELOQ® Transponder Kit																✓		
microID™ Programmer's Kit																	✓	
125 kHz microID™ Developer's Kit																	✓	
125 kHz Anticollision microID™ Developer's Kit																	✓	
13.56 MHz Anticollision microID™ Developer's Kit																	✓	
MCP2510 CAN Developer's Kit																	✓	✓

* Contact the Microchip Technology Inc. web site at www.microchip.com for information on how to use the MPLAB® ICD In-Circuit Debugger (DV164001) with PIC16C62, 63, 64, 65, 72, 73, 74, 76, 77.

** Contact Microchip Technology Inc. for availability date.

† Development tool is available on select devices.

PIC16F84A

NOTES:

9.0 ELECTRICAL CHARACTERISTICS

Absolute Maximum Ratings †

Ambient temperature under bias.....	-55°C to +125°C
Storage temperature	-65°C to +150°C
Voltage on any pin with respect to V _{SS} (except V _{DD} , $\overline{\text{MCLR}}$, and RA4)	-0.3V to (V _{DD} + 0.3V)
Voltage on V _{DD} with respect to V _{SS}	-0.3 to +7.5V
Voltage on $\overline{\text{MCLR}}$ with respect to V _{SS} ⁽¹⁾	-0.3 to +14V
Voltage on RA4 with respect to V _{SS}	-0.3 to +8.5V
Total power dissipation ⁽²⁾	800 mW
Maximum current out of V _{SS} pin	150 mA
Maximum current into V _{DD} pin	100 mA
Input clamp current, I _{IK} (V _I < 0 or V _I > V _{DD}).....	± 20 mA
Output clamp current, I _{OK} (V _O < 0 or V _O > V _{DD})	± 20 mA
Maximum output current sunk by any I/O pin.....	25 mA
Maximum output current sourced by any I/O pin	25 mA
Maximum current sunk by PORTA.....	80 mA
Maximum current sourced by PORTA.....	50 mA
Maximum current sunk by PORTB.....	150 mA
Maximum current sourced by PORTB	100 mA

Note 1: Voltage spikes below V_{SS} at the $\overline{\text{MCLR}}$ pin, inducing currents greater than 80 mA, may cause latch-up. Thus, a series resistor of 50-100Ω should be used when applying a “low” level to the $\overline{\text{MCLR}}$ pin rather than pulling this pin directly to V_{SS}.

2: Power dissipation is calculated as follows: $P_{dis} = V_{DD} \times \{I_{DD} - \sum I_{OH}\} + \sum \{(V_{DD} - V_{OH}) \times I_{OH}\} + \sum (V_{OL} \times I_{OL})$.

† NOTICE: Stresses above those listed under “Absolute Maximum Ratings” may cause permanent damage to the device. This is a stress rating only and functional operation of the device at those or any other conditions above those indicated in the operation listings of this specification is not implied. Exposure to maximum rating conditions for extended periods may affect device reliability.

PIC16F84A

FIGURE 9-1: PIC16F84A-20 VOLTAGE-FREQUENCY GRAPH

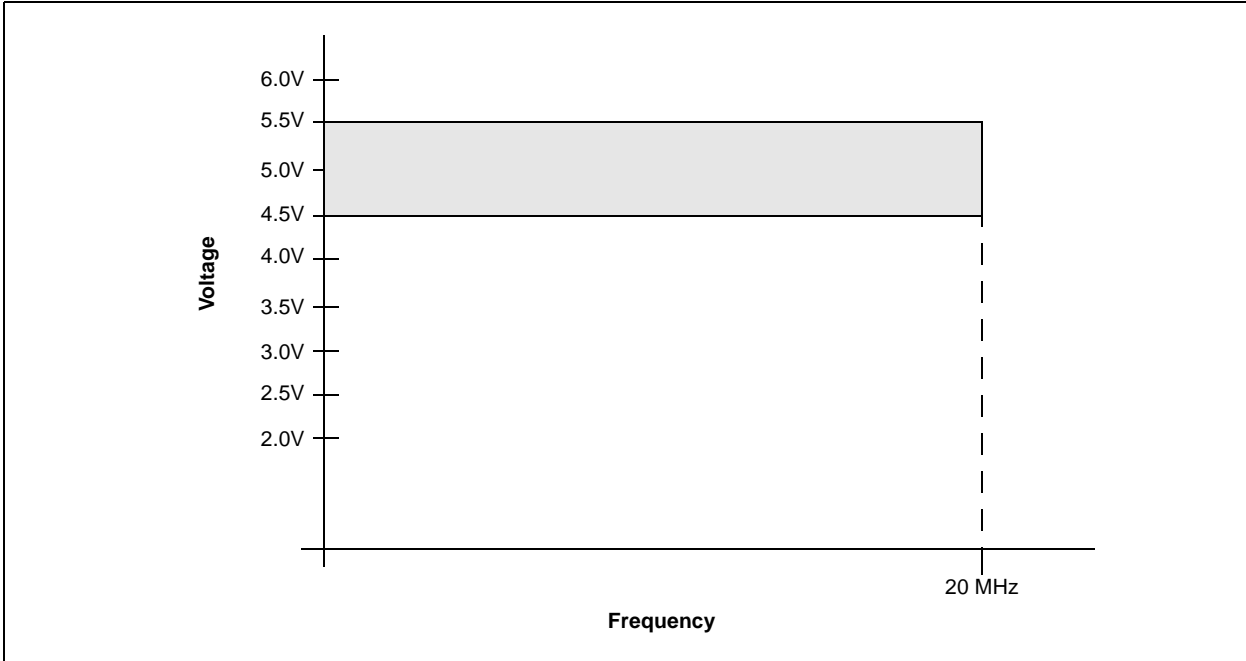

FIGURE 9-2: PIC16LF84A-04 VOLTAGE-FREQUENCY GRAPH

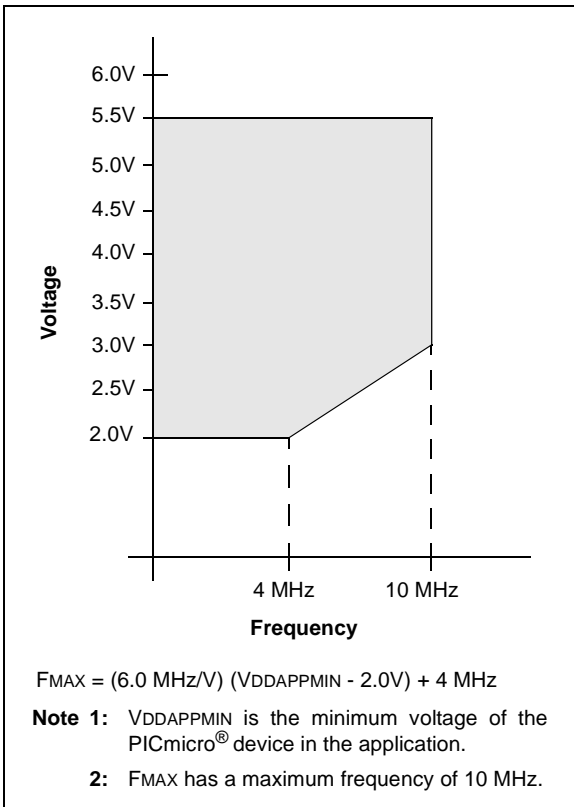
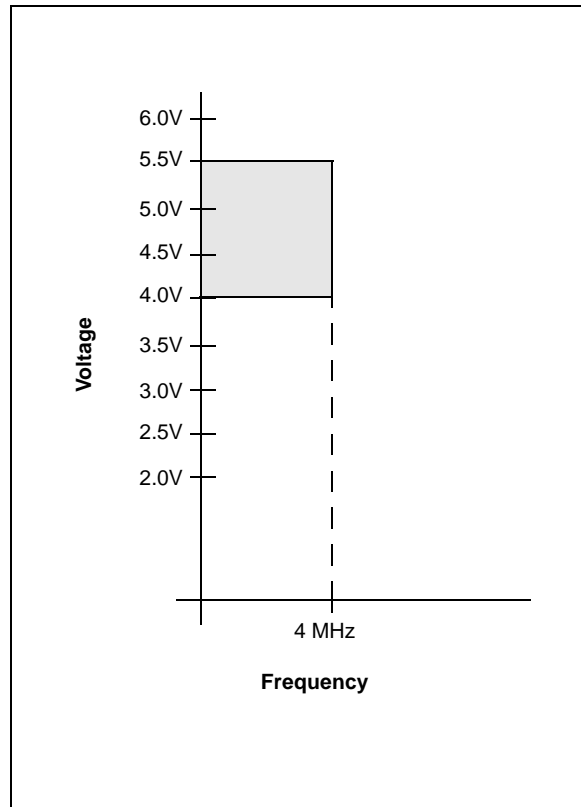

FIGURE 9-3: PIC16F84A-04 VOLTAGE-FREQUENCY GRAPH



9.1 DC Characteristics

PIC16LF84A-04 (Commercial, Industrial)		Standard Operating Conditions (unless otherwise stated) Operating temperature $0^{\circ}\text{C} \leq T_A \leq +70^{\circ}\text{C}$ (commercial) $-40^{\circ}\text{C} \leq T_A \leq +85^{\circ}\text{C}$ (industrial) $-40^{\circ}\text{C} \leq T_A \leq +125^{\circ}\text{C}$ (extended)					
PIC16F84A-04 (Commercial, Industrial, Extended) PIC16F84A-20 (Commercial, Industrial, Extended)		Standard Operating Conditions (unless otherwise stated) Operating temperature $0^{\circ}\text{C} \leq T_A \leq +70^{\circ}\text{C}$ (commercial) $-40^{\circ}\text{C} \leq T_A \leq +85^{\circ}\text{C}$ (industrial) $-40^{\circ}\text{C} \leq T_A \leq +125^{\circ}\text{C}$ (extended)					
Param No.	Symbol	Characteristic	Min	Typ†	Max	Units	Conditions
D001	VDD	Supply Voltage					
		16LF84A	2.0	—	5.5	V	XT, RC, and LP osc configuration
D001 D001A		16F84A	4.0	—	5.5	V	XT, RC and LP osc configuration
			4.5	—	5.5	V	HS osc configuration
D002	VDR	RAM Data Retention Voltage (Note 1)	1.5	—	—	V	Device in SLEEP mode
D003	VPOR	VDD Start Voltage to ensure internal Power-on Reset signal	—	VSS	—	V	See section on Power-on Reset for details
D004	SVDD	VDD Rise Rate to ensure internal Power-on Reset signal	0.05	—	—	V/ms	
D010 D010 D010A D013 D014	IDD	Supply Current (Note 2)					
		16LF84A	—	1	4	mA	RC and XT osc configuration (Note 4) FOSC = 2.0 MHz, VDD = 5.5V
		16F84A	—	1.8	4.5	mA	RC and XT osc configuration (Note 4) FOSC = 4.0 MHz, VDD = 5.5V
			—	3	10	mA	RC and XT osc configuration (Note 4) FOSC = 4.0 MHz, VDD = 5.5V (During FLASH programming)
			—	10	20	mA	HS osc configuration (PIC16F84A-20) FOSC = 20 MHz, VDD = 5.5V
		16LF84A	—	15	45	μA	LP osc configuration FOSC = 32 kHz, VDD = 2.0V, WDT disabled

Legend: Rows with standard voltage device data only are shaded for improved readability.

† Data in "Typ" column is at 5.0V, 25°C unless otherwise stated. These parameters are for design guidance only and are not tested.

NR Not rated for operation.

Note 1: This is the limit to which VDD can be lowered without losing RAM data.

2: The supply current is mainly a function of the operating voltage and frequency. Other factors, such as I/O pin loading and switching rate, oscillator type, internal code execution pattern, and temperature also have an impact on the current consumption.

The test conditions for all IDD measurements in active operation mode are:

OSC1 = external square wave, from rail-to-rail; all I/O pins tri-stated, pulled to VDD,
T0CKI = VDD, MCLR = VDD; WDT enabled/disabled as specified.

3: The power-down current in SLEEP mode does not depend on the oscillator type. Power-down current is measured with the part in SLEEP mode, with all I/O pins in hi-impedance state and tied to VDD and VSS.

4: For RC osc configuration, current through REXT is not included. The current through the resistor can be estimated by the formula $I_R = V_{DD}/2R_{EXT}$ (mA) with REXT in kOhm.

5: The Δ current is the additional current consumed when this peripheral is enabled. This current should be added to the base IDD measurement.

PIC16F84A

9.1 DC Characteristics (Continued)

PIC16LF84A-04 (Commercial, Industrial)		Standard Operating Conditions (unless otherwise stated) Operating temperature 0°C ≤ TA ≤ +70°C (commercial) -40°C ≤ TA ≤ +85°C (industrial) -40°C ≤ TA ≤ +125°C (extended)					
PIC16F84A-04 (Commercial, Industrial, Extended) PIC16F84A-20 (Commercial, Industrial, Extended)		Standard Operating Conditions (unless otherwise stated) Operating temperature 0°C ≤ TA ≤ +70°C (commercial) -40°C ≤ TA ≤ +85°C (industrial) -40°C ≤ TA ≤ +125°C (extended)					
Param No.	Symbol	Characteristic	Min	Typ†	Max	Units	Conditions
D020	IPD	Power-down Current (Note 3)					
		16LF84A					
D020		16F84A-20 16F84A-04					
D021A		16LF84A	—	0.4	1.0	μA	VDD = 2.0V, WDT disabled, industrial
D021A		16F84A-20	—	1.5	3.5	μA	VDD = 4.5V, WDT disabled, industrial
		16F84A-04	—	1.0	3.0	μA	VDD = 4.0V, WDT disabled, industrial
D021B		16F84A-20	—	1.5	5.5	μA	VDD = 4.5V, WDT disabled, extended
		16F84A-04	—	1.0	5.0	μA	VDD = 4.0V, WDT disabled, extended
D022	ΔI _{WDT}	Module Differential Current (Note 5) Watchdog Timer	—	.20	16	μA	VDD = 2.0V, Industrial, Commercial
			—	3.5	20	μA	VDD = 4.0V, Commercial
			—	3.5	28	μA	VDD = 4.0V, Industrial, Extended
			—	4.8	25	μA	VDD = 4.5V, Commercial
			—	4.8	30	μA	VDD = 4.5V, Industrial, Extended

Legend: Rows with standard voltage device data only are shaded for improved readability.

† Data in "Typ" column is at 5.0V, 25°C unless otherwise stated. These parameters are for design guidance only and are not tested.

NR Not rated for operation.

Note 1: This is the limit to which VDD can be lowered without losing RAM data.

2: The supply current is mainly a function of the operating voltage and frequency. Other factors, such as I/O pin loading and switching rate, oscillator type, internal code execution pattern, and temperature also have an impact on the current consumption.

The test conditions for all IDD measurements in active operation mode are:

OSC1 = external square wave, from rail-to-rail; all I/O pins tri-stated, pulled to VDD,

T0CKI = VDD, MCLR = VDD; WDT enabled/disabled as specified.

3: The power-down current in SLEEP mode does not depend on the oscillator type. Power-down current is measured with the part in SLEEP mode, with all I/O pins in hi-impedance state and tied to VDD and VSS.

4: For RC osc configuration, current through REXT is not included. The current through the resistor can be estimated by the formula $I_R = V_{DD}/2R_{EXT}$ (mA) with REXT in kOhm.

5: The Δ current is the additional current consumed when this peripheral is enabled. This current should be added to the base IDD measurement.

9.2 DC Characteristics: **PIC16F84A-04 (Commercial, Industrial)**
PIC16F84A-20 (Commercial, Industrial)
PIC16LF84A-04 (Commercial, Industrial)

DC Characteristics All Pins Except Power Supply Pins		Standard Operating Conditions (unless otherwise stated) Operating temperature $0^{\circ}\text{C} \leq T_A \leq +70^{\circ}\text{C}$ (commercial) $-40^{\circ}\text{C} \leq T_A \leq +85^{\circ}\text{C}$ (industrial) Operating voltage V_{DD} range as described in DC specifications (Section 9.1)					
Param No.	Symbol	Characteristic	Min	Typ†	Max	Units	Conditions
D030 D030A D031 D032 D033 D034	V_{IL}	Input Low Voltage I/O ports: with TTL buffer with Schmitt Trigger buffer $\overline{\text{MCLR}}$, RA4/T0CKI OSC1 (XT, HS and LP modes) OSC1 (RC mode)	V_{SS} V_{SS} V_{SS} V_{SS} V_{SS} V_{SS}	— — — — — —	0.8 0.16 V_{DD} 0.2 V_{DD} 0.2 V_{DD} 0.3 V_{DD} 0.1 V_{DD}	V V V V V V	$4.5\text{V} \leq V_{DD} \leq 5.5\text{V}$ (Note 4) Entire range (Note 4) Entire range (Note 1)
D040 D040A D041 D042 D042A D043 D043A	V_{IH}	Input High Voltage I/O ports: with TTL buffer with Schmitt Trigger buffer $\overline{\text{MCLR}}$, RA4/T0CKI OSC1 (XT, HS and LP modes) OSC1 (RC mode)	2.0 0.25 $V_{DD}+0.8$ 0.8 V_{DD} 0.8 V_{DD} 0.8 V_{DD} 0.8 V_{DD} 0.9 V_{DD}	— — — — — — —	V_{DD} V_{DD} V_{DD} V_{DD} 8.5 V_{DD} V_{DD}	V V V V V V V	$4.5\text{V} \leq V_{DD} \leq 5.5\text{V}$ (Note 4) Entire range (Note 4) Entire range (Note 1)
D050	V_{HYS}	Hysteresis of Schmitt Trigger Inputs	—	0.1	—	V	
D070	IPURB	PORTB Weak Pull-up Current	50	250	400	μA	$V_{DD} = 5.0\text{V}$, $V_{PIN} = V_{SS}$
D060 D061 D063	I_{IL}	Input Leakage Current (Notes 2, 3) I/O ports $\overline{\text{MCLR}}$, RA4/T0CKI OSC1	— — —	— — —	± 1 ± 5 ± 5	μA μA μA	$V_{SS} \leq V_{PIN} \leq V_{DD}$, Pin at hi-impedance $V_{SS} \leq V_{PIN} \leq V_{DD}$ $V_{SS} \leq V_{PIN} \leq V_{DD}$, XT, HS and LP osc configuration

† Data in "Typ" column is at 5.0V, 25°C unless otherwise stated. These parameters are for design guidance only and are not tested.

- Note 1:** In RC oscillator configuration, the OSC1 pin is a Schmitt Trigger input. Do not drive the PIC16F84A with an external clock while the device is in RC mode, or chip damage may result.
- 2:** The leakage current on the $\overline{\text{MCLR}}$ pin is strongly dependent on the applied voltage level. The specified levels represent normal operating conditions. Higher leakage current may be measured at different input voltages.
- 3:** Negative current is defined as coming out of the pin.
- 4:** The user may choose the better of the two specs.

PIC16F84A

9.2 DC Characteristics: PIC16F84A-04 (Commercial, Industrial) PIC16F84A-20 (Commercial, Industrial) PIC16LF84A-04 (Commercial, Industrial) (Continued)

DC Characteristics All Pins Except Power Supply Pins			Standard Operating Conditions (unless otherwise stated) Operating temperature $0^{\circ}\text{C} \leq T_A \leq +70^{\circ}\text{C}$ (commercial) $-40^{\circ}\text{C} \leq T_A \leq +85^{\circ}\text{C}$ (industrial) Operating voltage V_{DD} range as described in DC specifications (Section 9.1)				
Param No.	Symbol	Characteristic	Min	Typ†	Max	Units	Conditions
D080 D083	V_{OL}	Output Low Voltage I/O ports OSC2/CLKOUT	—	—	0.6	V	$I_{OL} = 8.5\text{ mA}$, $V_{DD} = 4.5\text{ V}$ $I_{OL} = 1.6\text{ mA}$, $V_{DD} = 4.5\text{ V}$, (RC mode only)
D090 D092	V_{OH}	Output High Voltage I/O ports (Note 3) OSC2/CLKOUT (Note 3)	$V_{DD}-0.7$ $V_{DD}-0.7$	— —	— —	V V	$I_{OH} = -3.0\text{ mA}$, $V_{DD} = 4.5\text{ V}$ $I_{OH} = -1.3\text{ mA}$, $V_{DD} = 4.5\text{ V}$ (RC mode only)
D150	V_{OD}	Open Drain High Voltage RA4 pin	—	—	8.5	V	
D100 D101	C_{osc2} C_{IO}	Capacitive Loading Specs on Output Pins OSC2 pin All I/O pins and OSC2 (RC mode)	— —	— —	15 50	pF pF	In XT, HS and LP modes when external clock is used to drive OSC1
D120 D121 D122	ED V_{DRW} TDEW	Data EEPROM Memory Endurance V_{DD} for read/write Erase/Write cycle time	1M V_{MIN} —	10M — 4	— 5.5 8	E/W V ms	25°C at 5V V_{MIN} = Minimum operating voltage
D130 D131 D132 D133	EP V_{PR} V_{PEW} TPEW	Program FLASH Memory Endurance V_{DD} for read V_{DD} for erase/write Erase/Write cycle time	1000 V_{MIN} 4.5 —	10K — — 4	— 5.5 5.5 8	E/W V V ms	V_{MIN} = Minimum operating voltage

† Data in "Typ" column is at 5.0V, 25°C unless otherwise stated. These parameters are for design guidance only and are not tested.

- Note 1:** In RC oscillator configuration, the OSC1 pin is a Schmitt Trigger input. Do not drive the PIC16F84A with an external clock while the device is in RC mode, or chip damage may result.
- 2:** The leakage current on the MCLR pin is strongly dependent on the applied voltage level. The specified levels represent normal operating conditions. Higher leakage current may be measured at different input voltages.
- 3:** Negative current is defined as coming out of the pin.
- 4:** The user may choose the better of the two specs.

9.3 AC (Timing) Characteristics

9.3.1 TIMING PARAMETER SYMBOLOGY

The timing parameter symbols have been created following one of the following formats:

1. TppS2ppS
2. TppS

T		T	
F	Frequency	Time	

Lowercase letters (pp) and their meanings:

pp		os, osc	OSC1
2	to	ost	oscillator start-up timer
ck	CLKOUT	pwrt	power-up timer
cy	cycle time	rbt	RBx pins
io	I/O port	t0	T0CKI
inp	INT pin	wdt	watchdog timer
mp	MCLR		

Uppercase letters and their meanings:

S		P	Period
F	Fall	R	Rise
H	High	V	Valid
I	Invalid (high impedance)	Z	High Impedance
L	Low		

PIC16F84A

9.3.2 TIMING CONDITIONS

The temperature and voltages specified in Table 9-1 apply to all timing specifications unless otherwise noted. All timings are measured between high and low measurement points as indicated in Figure 9-4. Figure 9-5 specifies the load conditions for the timing specifications.

TABLE 9-1: TEMPERATURE AND VOLTAGE SPECIFICATIONS - AC

AC CHARACTERISTICS	Standard Operating Conditions (unless otherwise stated)	
	Operating temperature	$0^{\circ}\text{C} \leq T_A \leq +70^{\circ}\text{C}$ for commercial $-40^{\circ}\text{C} \leq T_A \leq +85^{\circ}\text{C}$ for industrial
	Operating voltage V_{DD} range	as described in DC specifications (Section 9.1)

FIGURE 9-4: PARAMETER MEASUREMENT INFORMATION

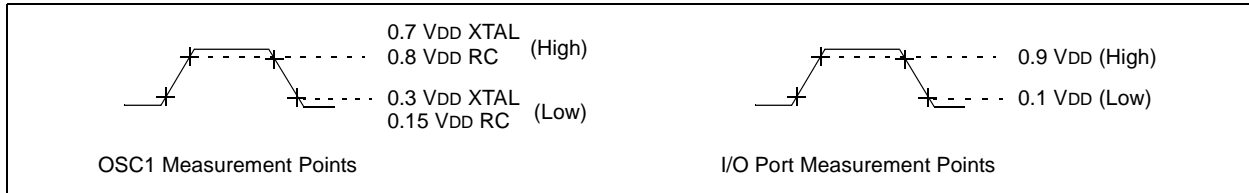
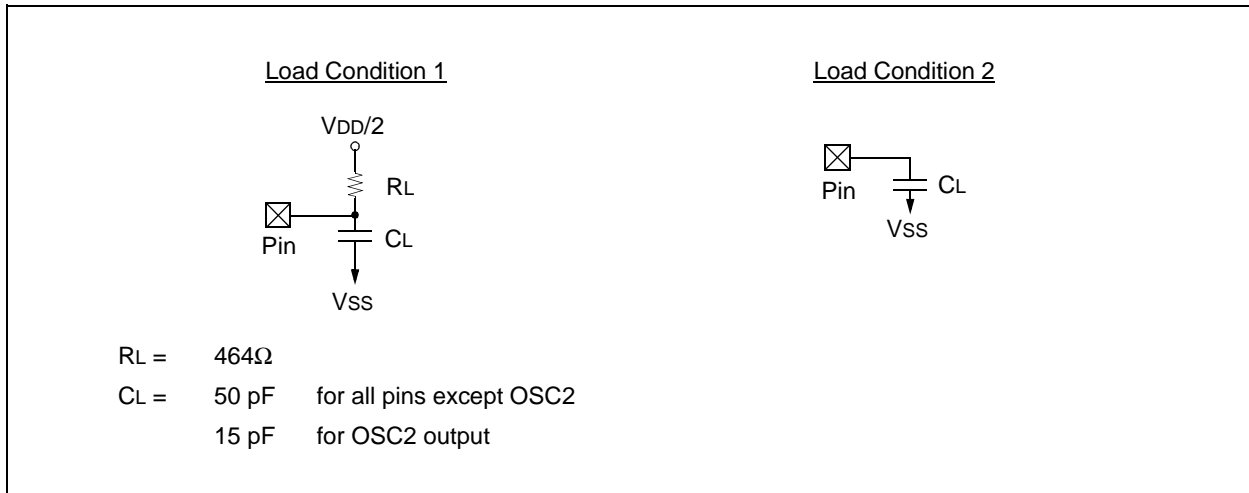

FIGURE 9-5: LOAD CONDITIONS



9.3.3 TIMING DIAGRAMS AND SPECIFICATIONS

FIGURE 9-6: EXTERNAL CLOCK TIMING

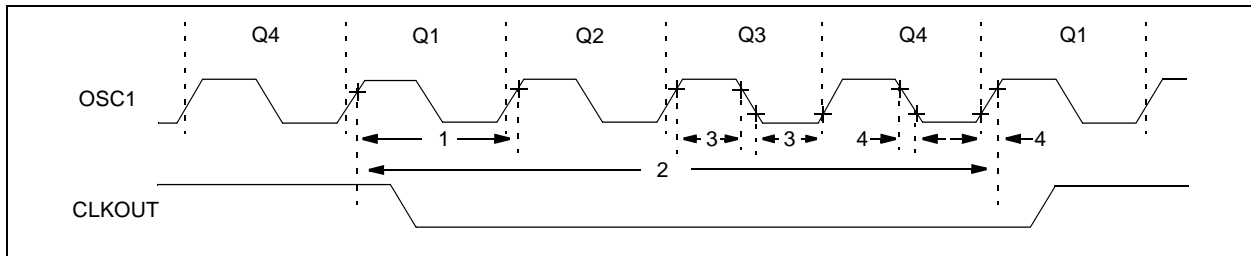

TABLE 9-2: EXTERNAL CLOCK TIMING REQUIREMENTS

Param No.	Sym	Characteristic	Min	Typ†	Max	Units	Conditions			
	Fosc	External CLKIN Frequency⁽¹⁾	DC	—	2	MHz	XT, RC osc (-04, LF)			
			DC	—	4	MHz	XT, RC osc (-04)			
			DC	—	20	MHz	HS osc (-20)			
			DC	—	200	kHz	LP osc (-04, LF)			
		Oscillator Frequency⁽¹⁾	DC	—	2	MHz	RC osc (-04, LF)			
			DC	—	4	MHz	RC osc (-04)			
			0.1	—	2	MHz	XT osc (-04, LF)			
			0.1	—	4	MHz	XT osc (-04)			
			1.0	—	20	MHz	HS osc (-20)			
			DC	—	200	kHz	LP osc (-04, LF)			
			1	Tosc	External CLKIN Period⁽¹⁾	500	—	—	ns	XT, RC osc (-04, LF)
			250			—	—	ns	XT, RC osc (-04)	
50	—	—	ns			HS osc (-20)				
5.0	—	—	µs			LP osc (-04, LF)				
		Oscillator Period⁽¹⁾	500	—	—	ns	RC osc (-04, LF)			
			250	—	—	ns	RC osc (-04)			
			500	—	10,000	ns	XT osc (-04, LF)			
			250	—	10,000	ns	XT osc (-04)			
			50	—	1,000	ns	HS osc (-20)			
			5.0	—	—	µs	LP osc (-04, LF)			
2	Tcy	Instruction Cycle Time⁽¹⁾	0.2	4/Fosc	DC	µs				
3	TosL, TosH	Clock in (OSC1) High or Low Time	60	—	—	ns	XT osc (-04, LF)			
			50	—	—	ns	XT osc (-04)			
			2.0	—	—	µs	LP osc (-04, LF)			
			17.5	—	—	ns	HS osc (-20)			
4	TosR, TosF	Clock in (OSC1) Rise or Fall Time	25	—	—	ns	XT osc (-04)			
			50	—	—	ns	LP osc (-04, LF)			
			7.5	—	—	ns	HS osc (-20)			

† Data in "Typ" column is at 5.0V, 25°C unless otherwise stated. These parameters are for design guidance only and are not tested.

Note 1: Instruction cycle period (Tcy) equals four times the input oscillator time-base period. All specified values are based on characterization data for that particular oscillator type under standard operating conditions with the device executing code. Exceeding these specified limits may result in an unstable oscillator operation and/or higher than expected current consumption. All devices are tested to operate at "Min." values with an external clock applied to the OSC1 pin.

When an external clock input is used, the "Max." cycle time limit is "DC" (no clock) for all devices.

PIC16F84A

FIGURE 9-7: CLKOUT AND I/O TIMING

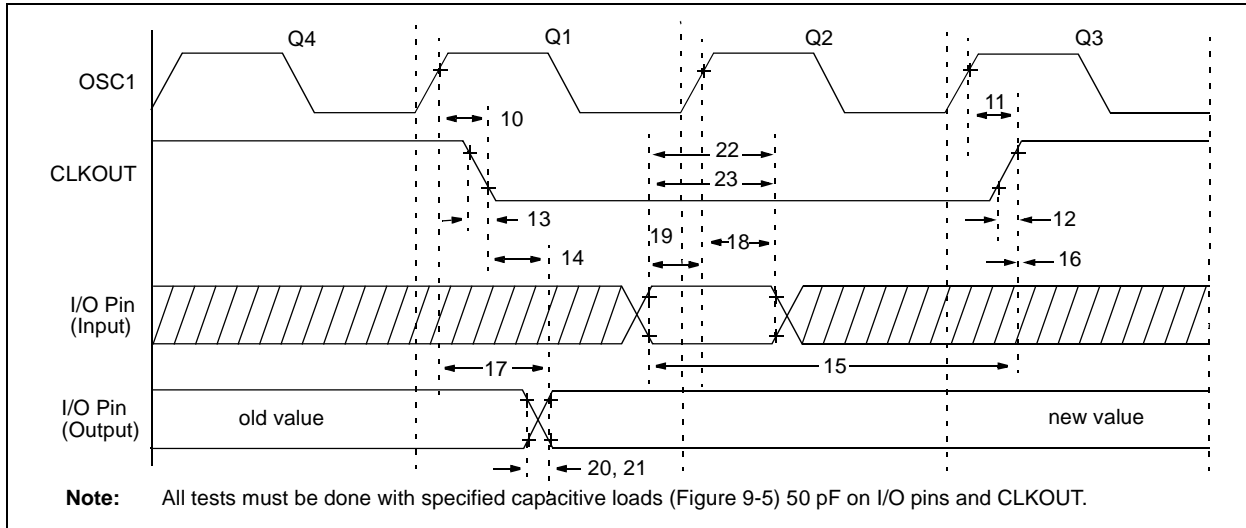

TABLE 9-3: CLKOUT AND I/O TIMING REQUIREMENTS

Param No.	Sym	Characteristic	Min	Typ†	Max	Units	Conditions	
10	TosH2ckL	OSC1↑ to CLKOUT↓	Standard	—	15	30	ns	(Note 1)
10A			Extended (LF)	—	15	120	ns	(Note 1)
11	TosH2ckH	OSC1↑ to CLKOUT↑	Standard	—	15	30	ns	(Note 1)
11A			Extended (LF)	—	15	120	ns	(Note 1)
12	TckR	CLKOUT rise time	Standard	—	15	30	ns	(Note 1)
12A			Extended (LF)	—	15	100	ns	(Note 1)
13	TckF	CLKOUT fall time	Standard	—	15	30	ns	(Note 1)
13A			Extended (LF)	—	15	100	ns	(Note 1)
14	TckL2ioV	CLKOUT ↓ to Port out valid	—	—	0.5Tcy + 20	ns	(Note 1)	
15	TioV2ckH	Port in valid before CLKOUT ↑	Standard	0.30Tcy + 30	—	—	ns	(Note 1)
			Extended (LF)	0.30Tcy + 80	—	—	ns	(Note 1)
16	TckH2ioI	Port in hold after CLKOUT ↑	0	—	—	ns	(Note 1)	
17	TosH2ioV	OSC1↑ (Q1 cycle) to Port out valid	Standard	—	—	125	ns	
			Extended (LF)	—	—	250	ns	
18	TosH2ioI	OSC1↑ (Q2 cycle) to Port input invalid (I/O in hold time)	Standard	10	—	—	ns	
			Extended (LF)	10	—	—	ns	
19	TioV2osH	Port input valid to OSC1↑ (I/O in setup time)	Standard	-75	—	—	ns	
			Extended (LF)	-175	—	—	ns	
20	TioR	Port output rise time	Standard	—	10	35	ns	
20A			Extended (LF)	—	10	70	ns	
21	TioF	Port output fall time	Standard	—	10	35	ns	
21A			Extended (LF)	—	10	70	ns	
22	TINP	INT pin high or low time	Standard	20	—	—	ns	
22A			Extended (LF)	55	—	—	ns	
23	TRBP	RB7:RB4 change INT high or low time	Standard	Tosc§	—	—	ns	
23A			Extended (LF)	Tosc§	—	—	ns	

† Data in "Typ" column is at 5.0V, 25°C unless otherwise stated. These parameters are for design guidance only and are not tested.

§ By design.

Note 1: Measurements are taken in RC mode where CLKOUT output is 4 x Tosc.

FIGURE 9-8: RESET, WATCHDOG TIMER, OSCILLATOR START-UP TIMER AND POWER-UP TIMER TIMING

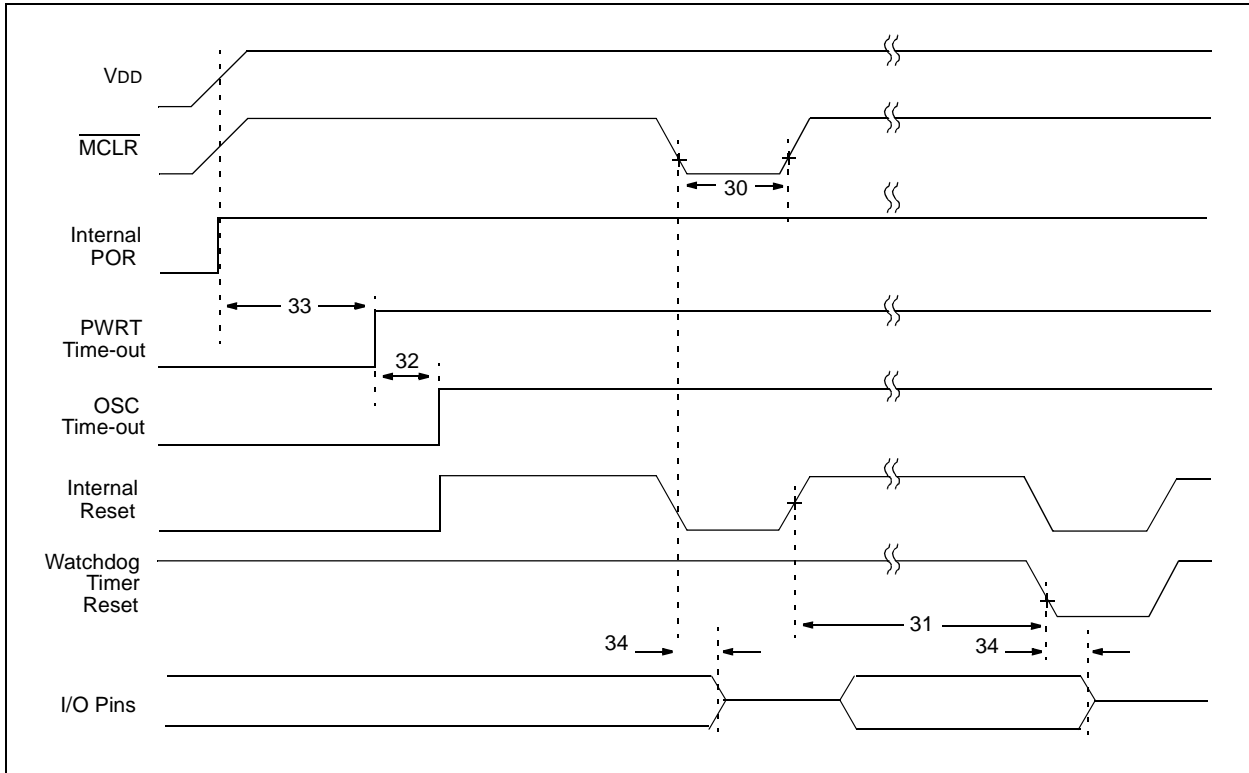

TABLE 9-4: RESET, WATCHDOG TIMER, OSCILLATOR START-UP TIMER AND POWER-UP TIMER REQUIREMENTS

Parameter No.	Sym	Characteristic	Min	Typ†	Max	Units	Conditions
30	Tmcl	MCLR Pulse Width (low)	2	—	—	μs	VDD = 5.0V
31	TWDT	Watchdog Timer Time-out Period (No Prescaler)	7	18	33	ms	VDD = 5.0V
32	TOST	Oscillation Start-up Timer Period		1024Tosc		ms	Tosc = OSC1 period
33	TPWRT	Power-up Timer Period	28	72	132	ms	VDD = 5.0V
34	Tioz	I/O hi-impedance from MCLR Low or RESET	—	—	100	ns	

† Data in "Typ" column is at 5V, 25°C, unless otherwise stated. These parameters are for design guidance only and are not tested.

PIC16F84A

FIGURE 9-9: TIMER0 CLOCK TIMINGS

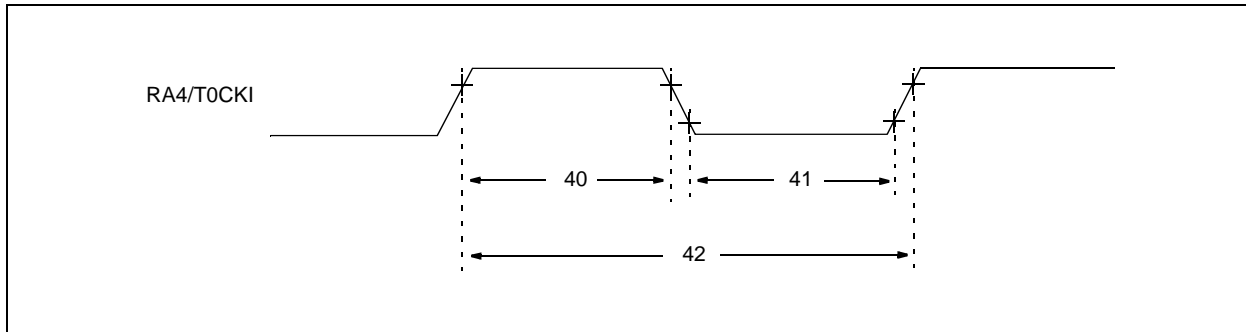

TABLE 9-5: TIMER0 CLOCK REQUIREMENTS

Parameter No.	Sym	Characteristic		Min	Typ†	Max	Units	Conditions
40	Tt0H	T0CKI High Pulse Width	No Prescaler	$0.5T_{CY} + 20$	—	—	ns	$2.0V \leq V_{DD} \leq 3.0V$ $3.0V \leq V_{DD} \leq 6.0V$
			With Prescaler	50 30	— —	— —	ns ns	
41	Tt0L	T0CKI Low Pulse Width	No Prescaler	$0.5T_{CY} + 20$	—	—	ns	$2.0V \leq V_{DD} \leq 3.0V$ $3.0V \leq V_{DD} \leq 6.0V$
			With Prescaler	50 20	— —	— —	ns ns	
42	Tt0P	T0CKI Period		$\frac{T_{CY} + 40}{N}$	—	—	ns	N = prescale value (2, 4, ..., 256)

† Data in "Typ" column is at 5.0V, 25°C, unless otherwise stated. These parameters are for design guidance only and are not tested.

10.0 DC/AC CHARACTERISTIC GRAPHS

The graphs provided in this section are for **design guidance** and are **not tested**.

In some graphs, the data presented are **outside specified operating range** (i.e., outside specified VDD range). This is for **information only** and devices are ensured to operate properly only within the specified range.

The data presented in this section is a **statistical summary** of data collected on units from different lots over a period of time and matrix samples. 'Typical' represents the mean of the distribution at 25°C. 'Max' or 'Min' represents (mean + 3 σ) or (mean - 3 σ), respectively, where σ is a standard deviation over the whole temperature range.

PIC16F84A

FIGURE 10-1: TYPICAL I_{DD} vs. F_{osc} OVER V_{DD} (HS MODE, 25°C)

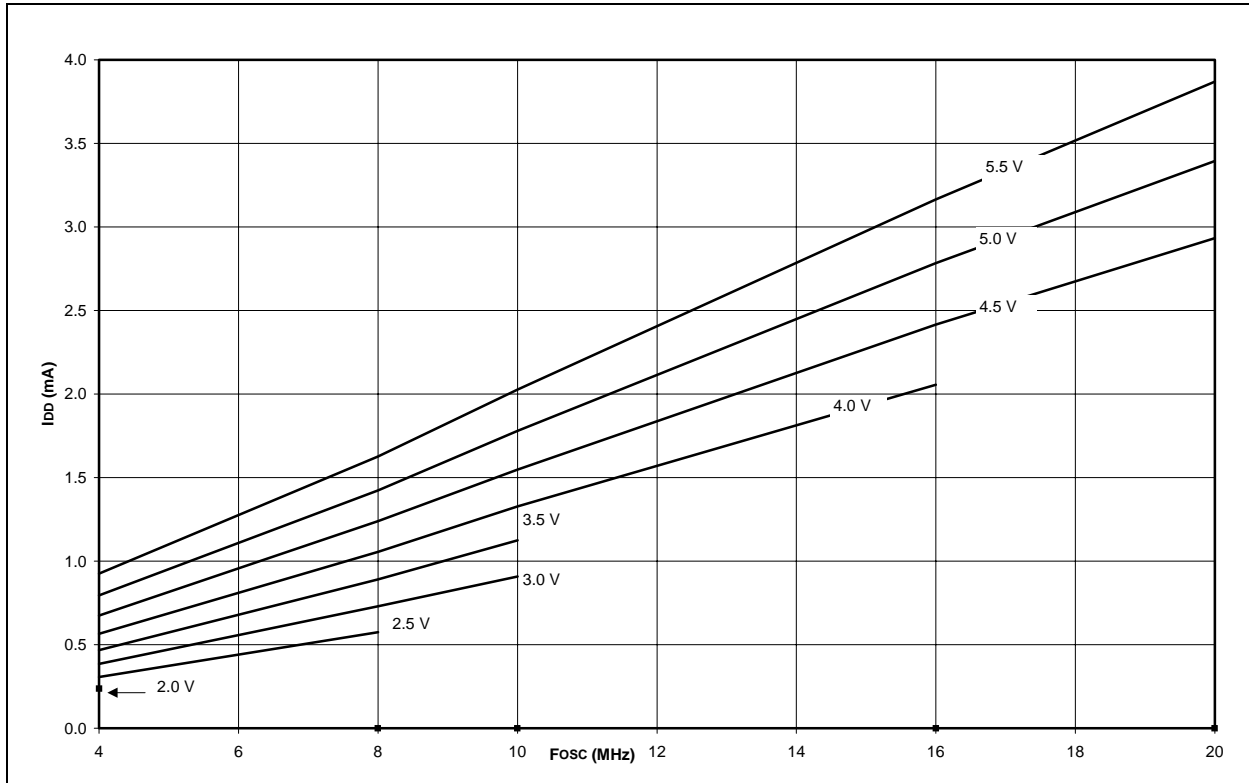

FIGURE 10-2: MAXIMUM I_{DD} vs. F_{osc} OVER V_{DD} (HS MODE, -40° TO +125°C)

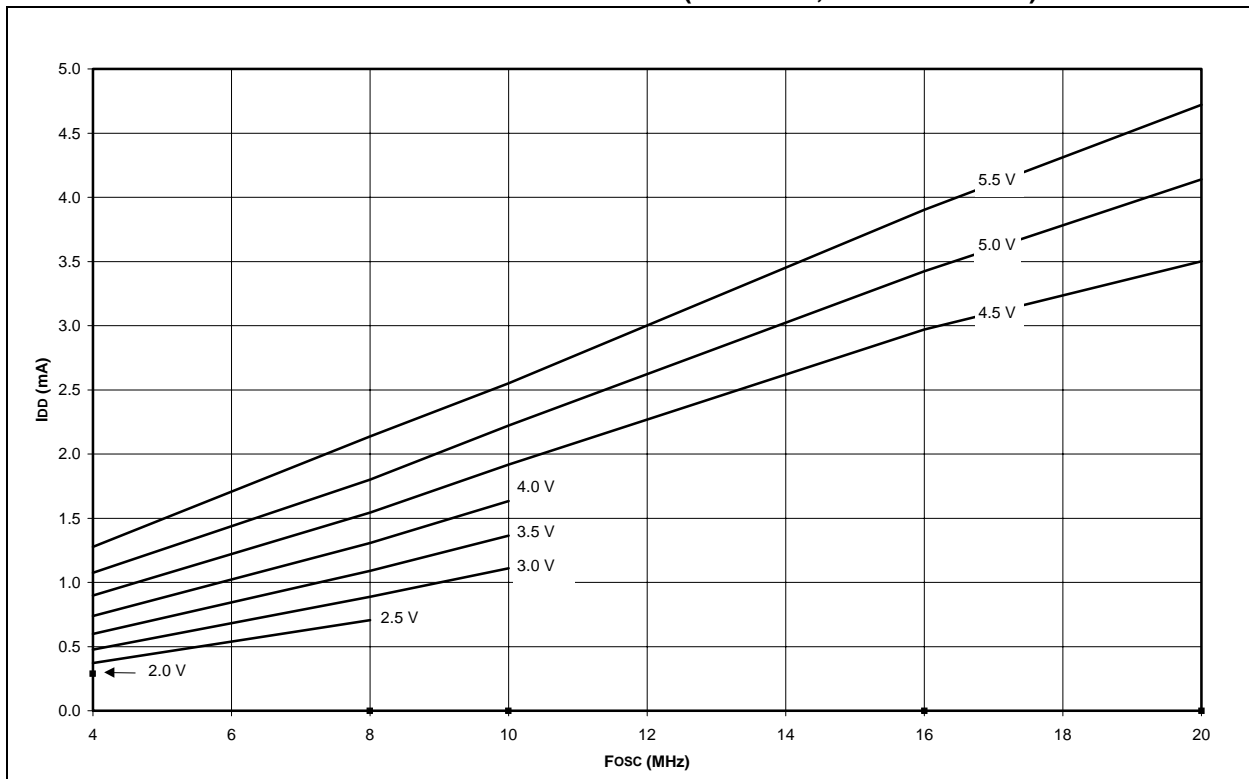

FIGURE 10-3: TYPICAL I_{DD} vs. F_{osc} OVER V_{DD} (XT MODE, 25°C)

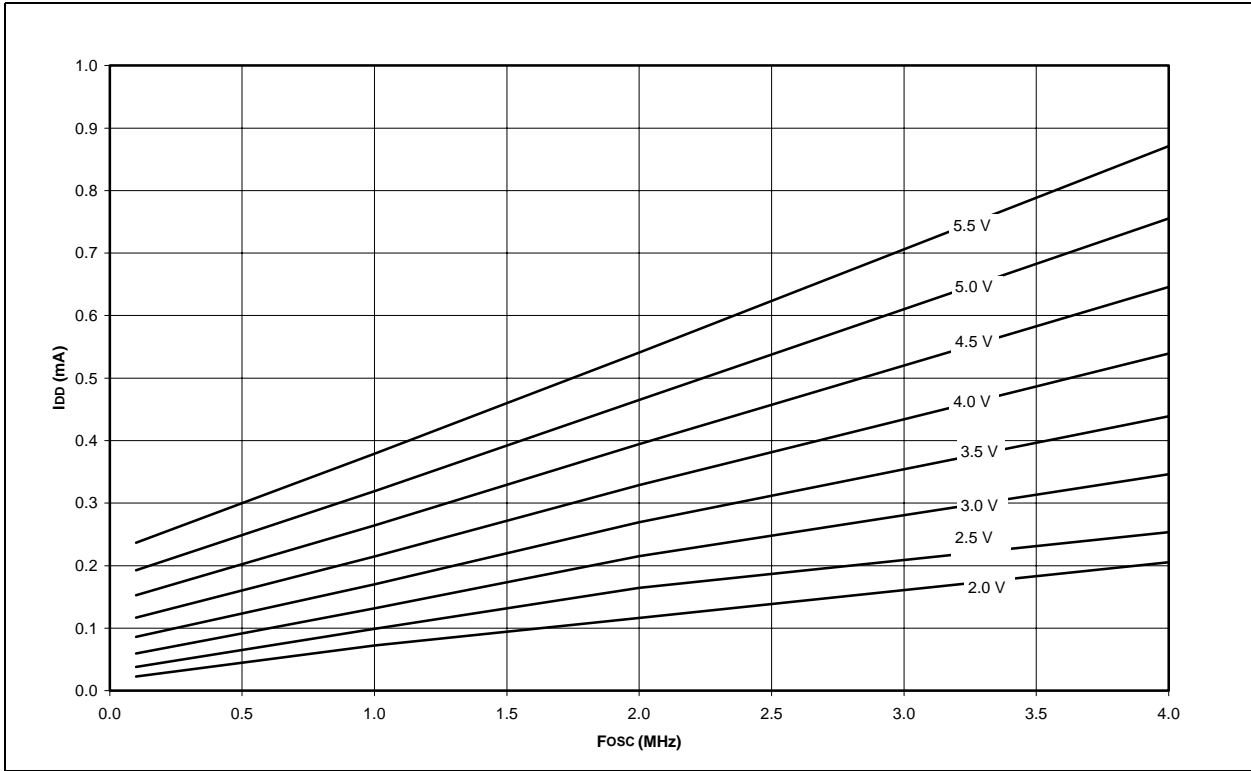
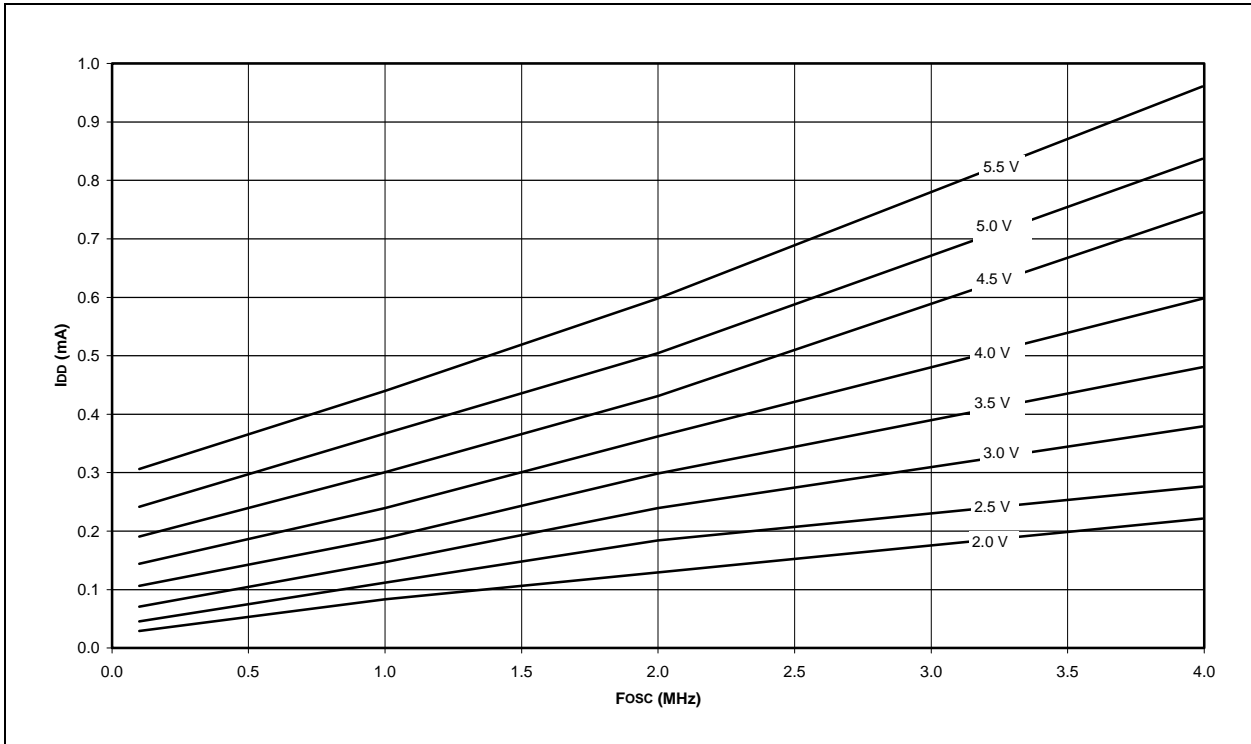

FIGURE 10-4: MAXIMUM I_{DD} vs. F_{osc} OVER V_{DD} (XT MODE, -40° TO +125°C)



PIC16F84A

FIGURE 10-5: TYPICAL I_{DD} vs. F_{osc} OVER V_{DD} (LP MODE, 25°C)

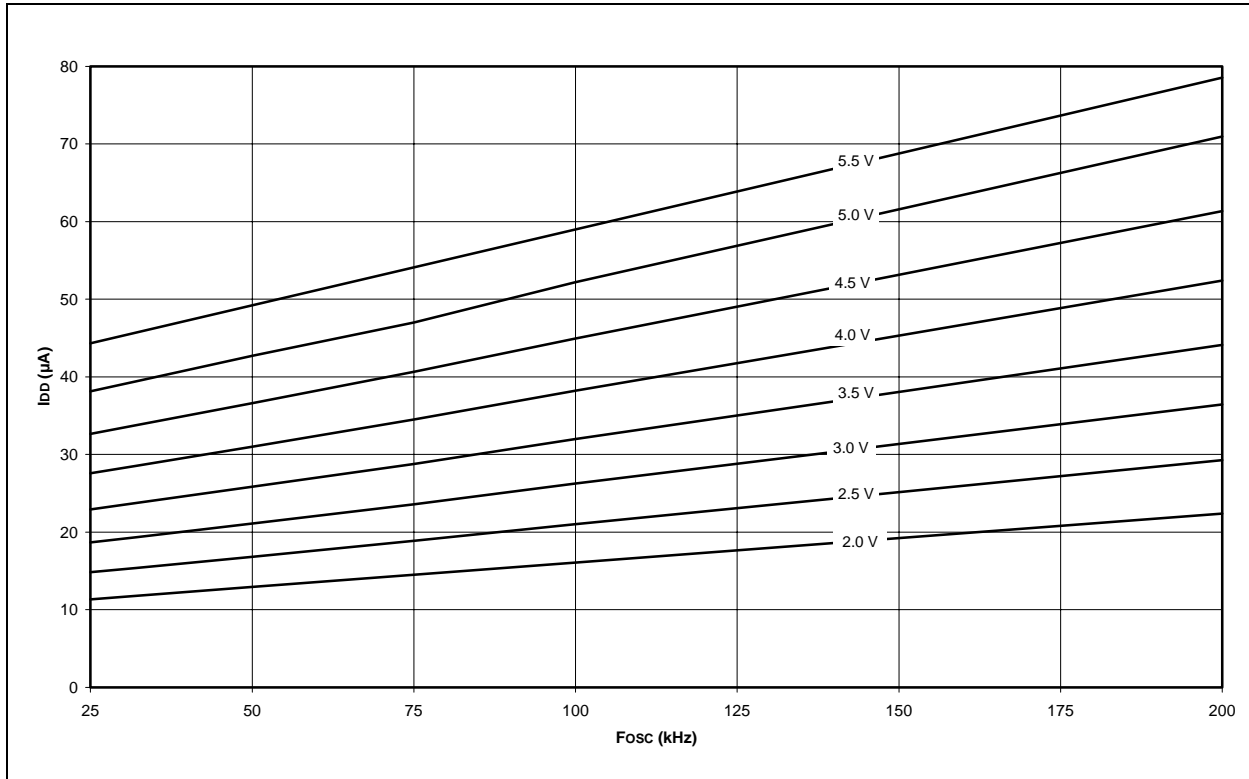

FIGURE 10-6: MAXIMUM I_{DD} vs. F_{osc} OVER V_{DD} (LP MODE, -40° TO +125°C)

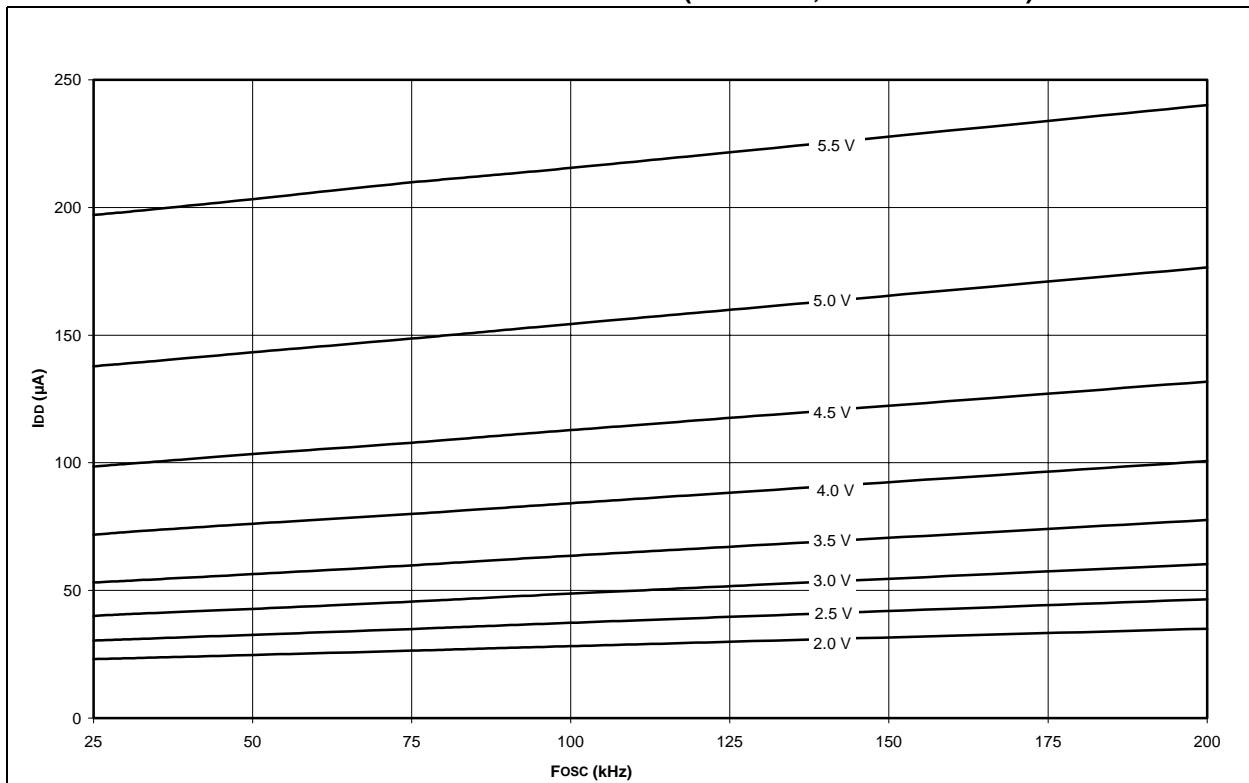

FIGURE 10-7: AVERAGE F_{osc} vs. V_{DD} FOR R (RC MODE, $C = 22\text{ pF}$, 25°C)

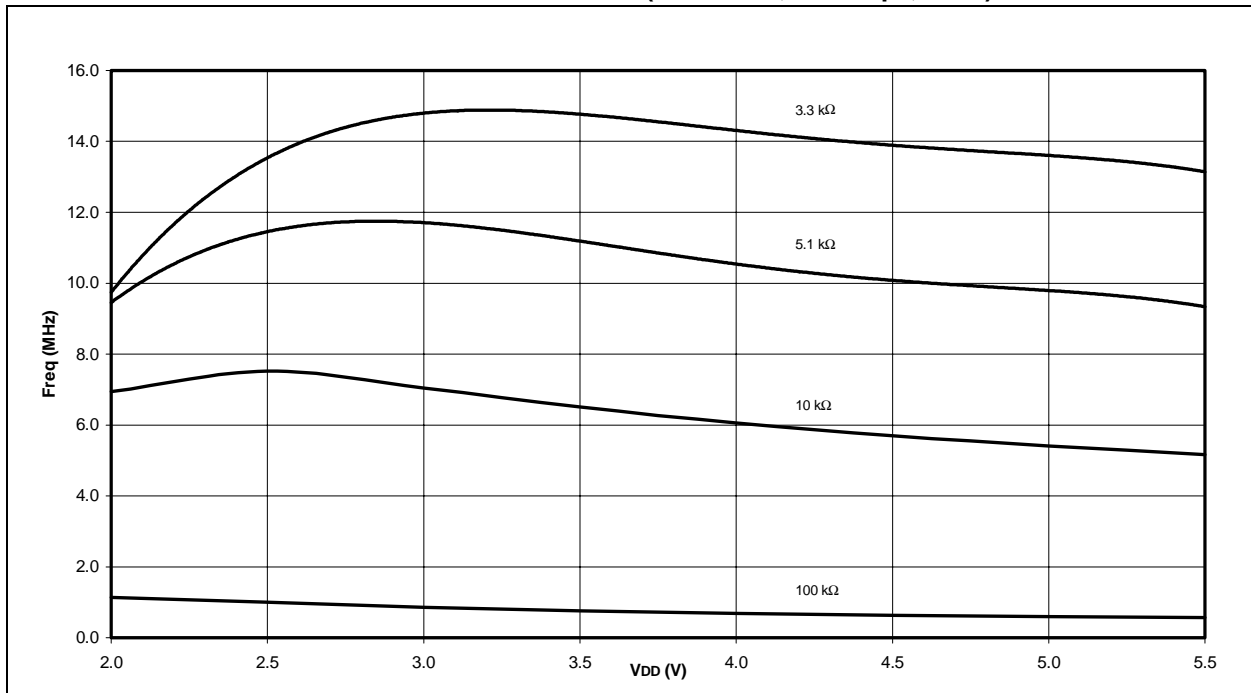
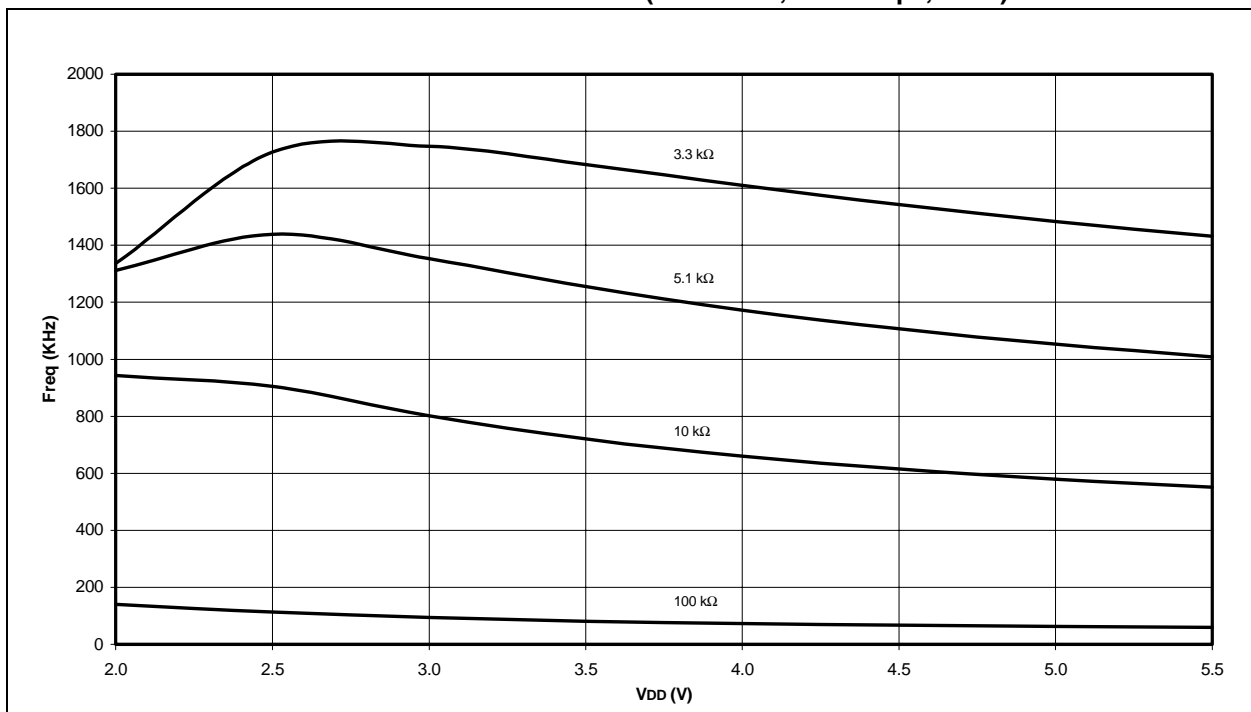

FIGURE 10-8: AVERAGE F_{osc} vs. V_{DD} FOR R (RC MODE, $C = 100\text{ pF}$, 25°C)



PIC16F84A

FIGURE 10-9: AVERAGE Fosc vs. VDD FOR R (RC MODE, C = 300 pF, 25°C)

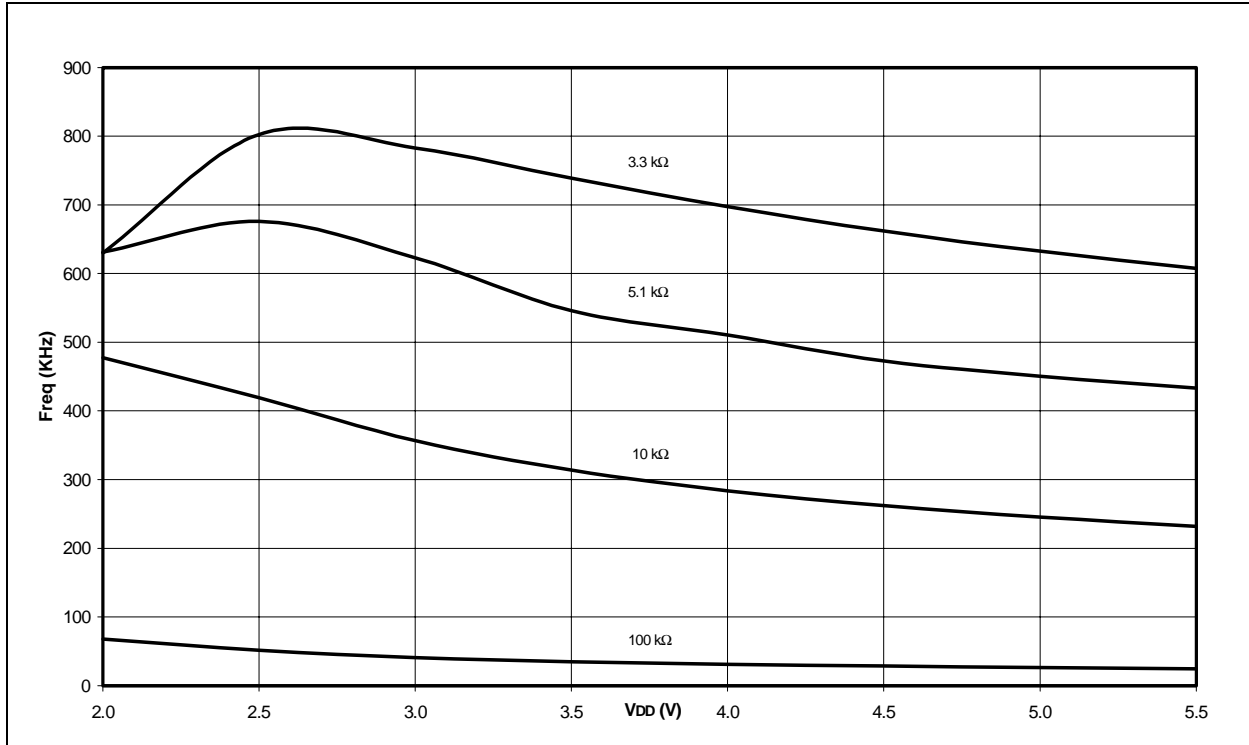

FIGURE 10-10: IPD vs. VDD (SLEEP MODE, ALL PERIPHERALS DISABLED)

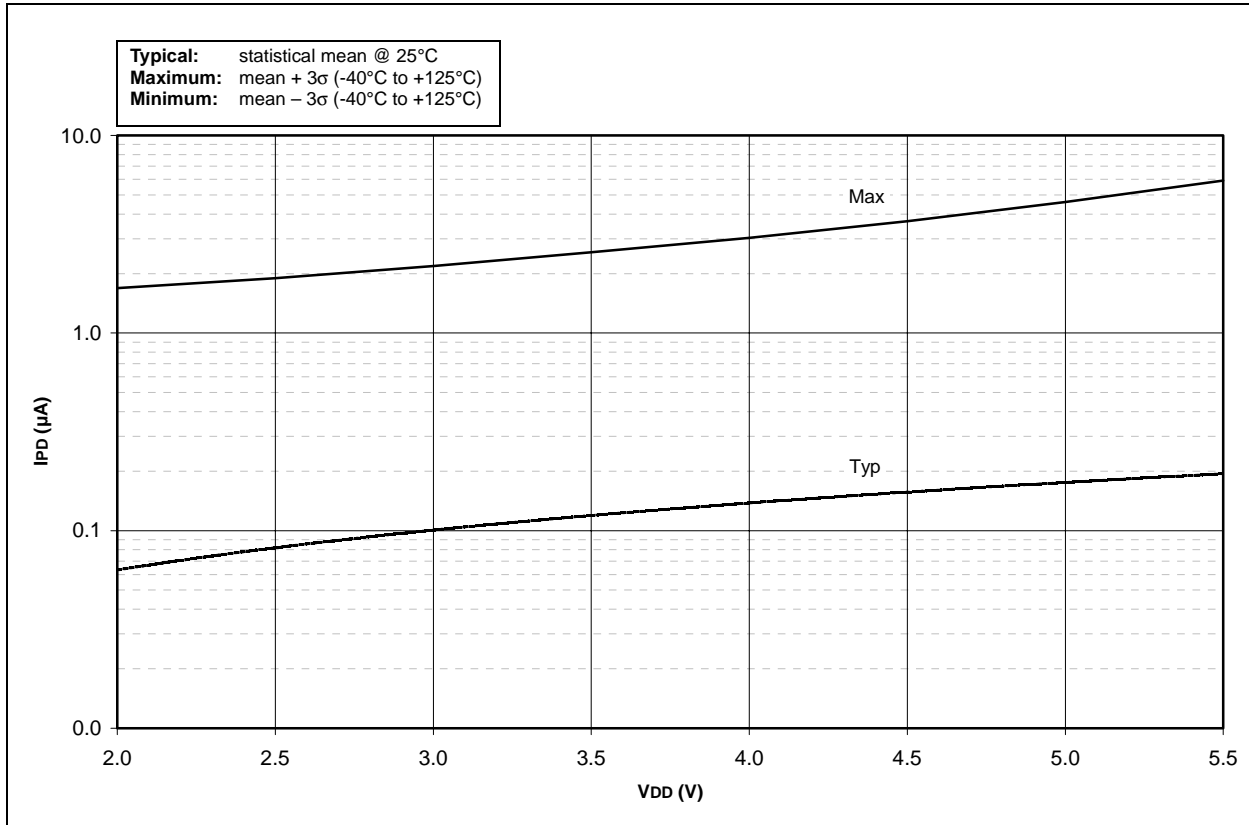

FIGURE 10-11: IPD vs. VDD (WDT MODE)

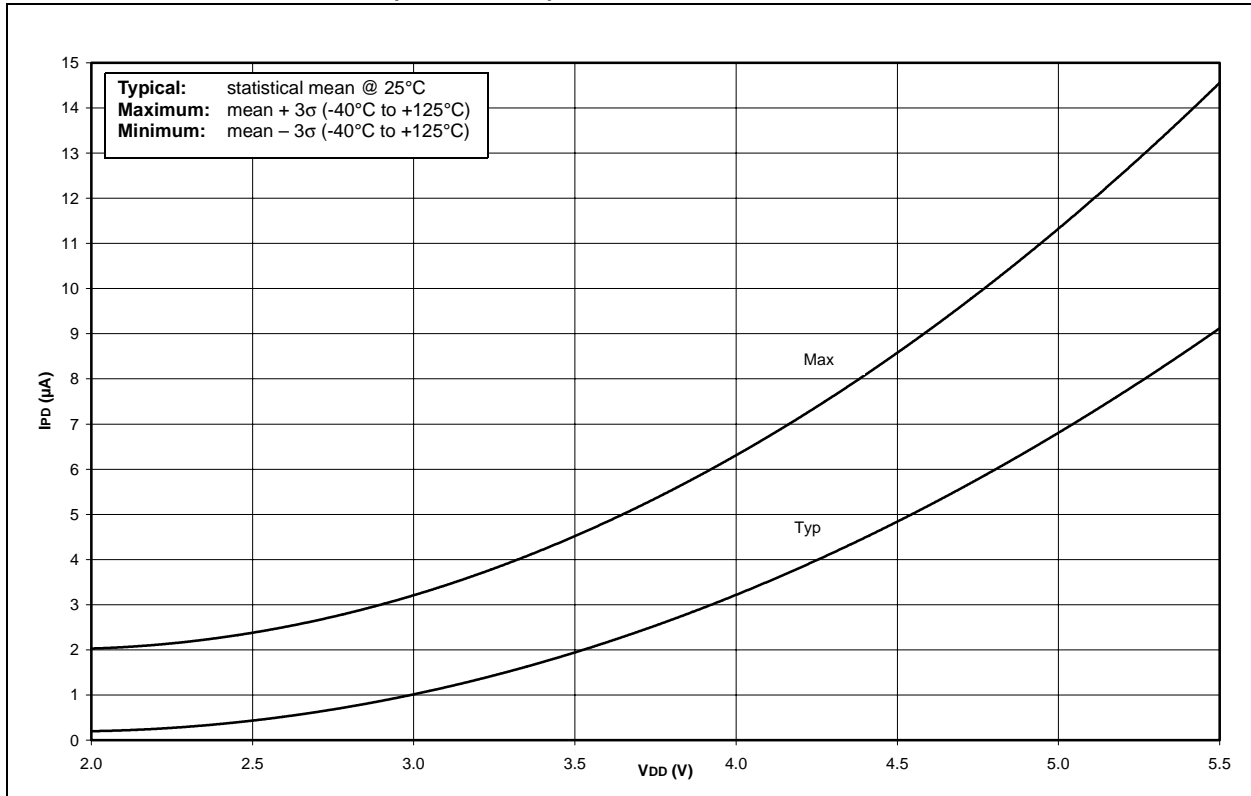
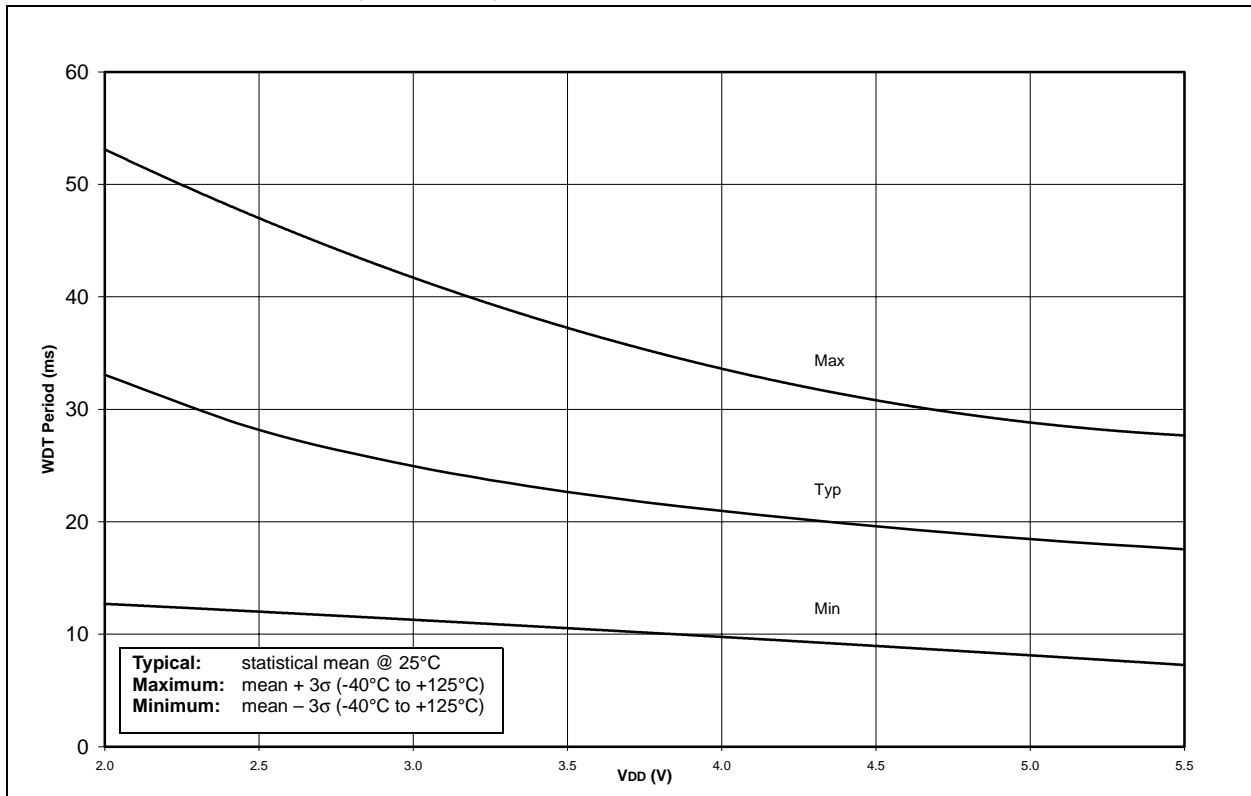

FIGURE 10-12: TYPICAL, MINIMUM, AND MAXIMUM WDT PERIOD vs. VDD OVER TEMP



PIC16F84A

FIGURE 10-13: TYPICAL, MINIMUM AND MAXIMUM V_{OH} vs. I_{OH} ($V_{DD} = 5V, -40^{\circ}C$ TO $+125^{\circ}C$)

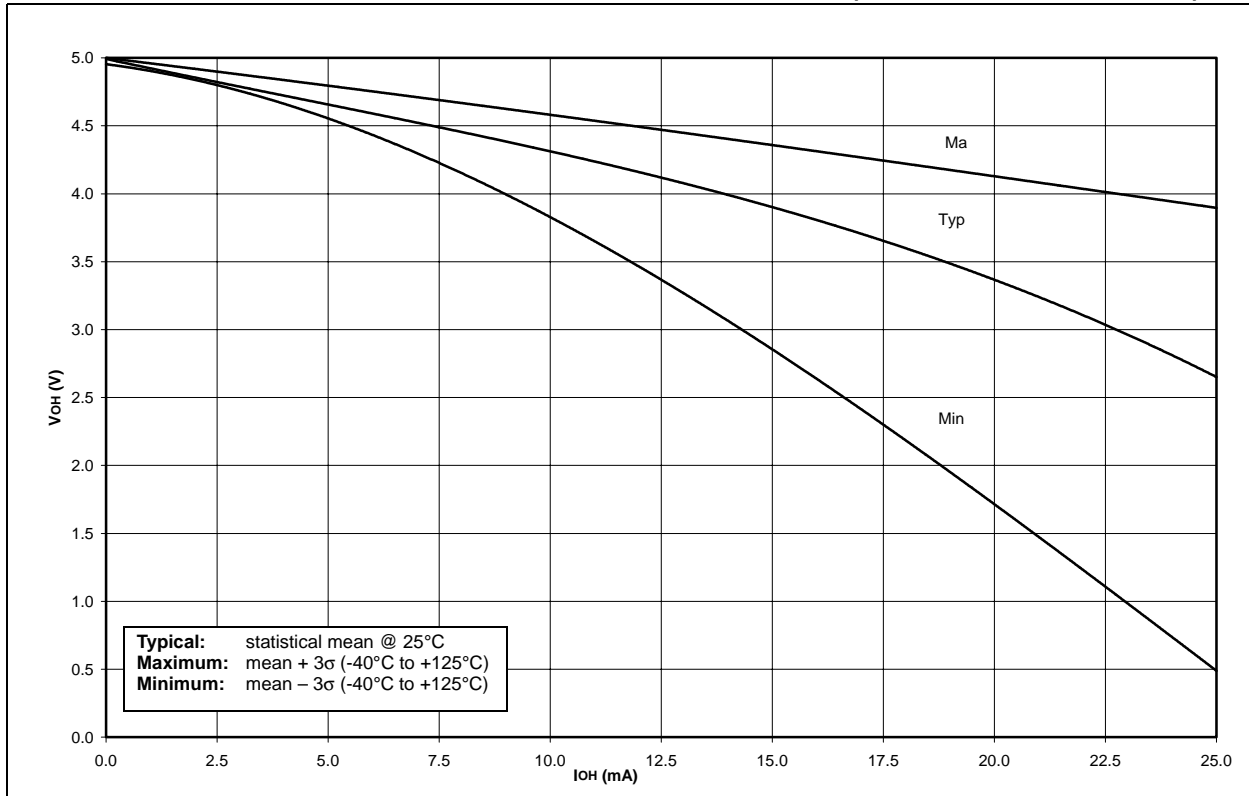

FIGURE 10-14: TYPICAL, MINIMUM AND MAXIMUM V_{OH} vs. I_{OH} ($V_{DD} = 3V, -40^{\circ}C$ TO $+125^{\circ}C$)

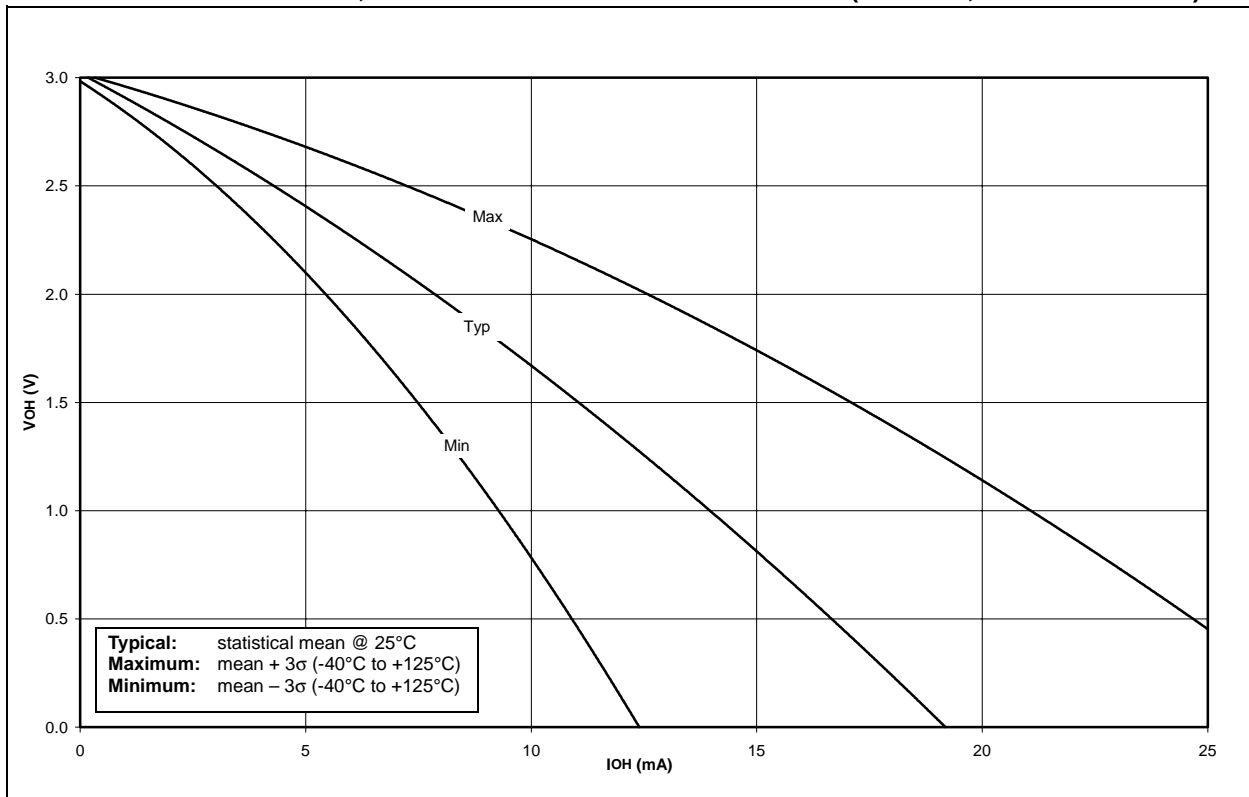

FIGURE 10-15: TYPICAL, MINIMUM AND MAXIMUM V_{OL} vs. I_{OL} ($V_{DD} = 5V$, $-40^{\circ}C$ TO $+125^{\circ}C$)

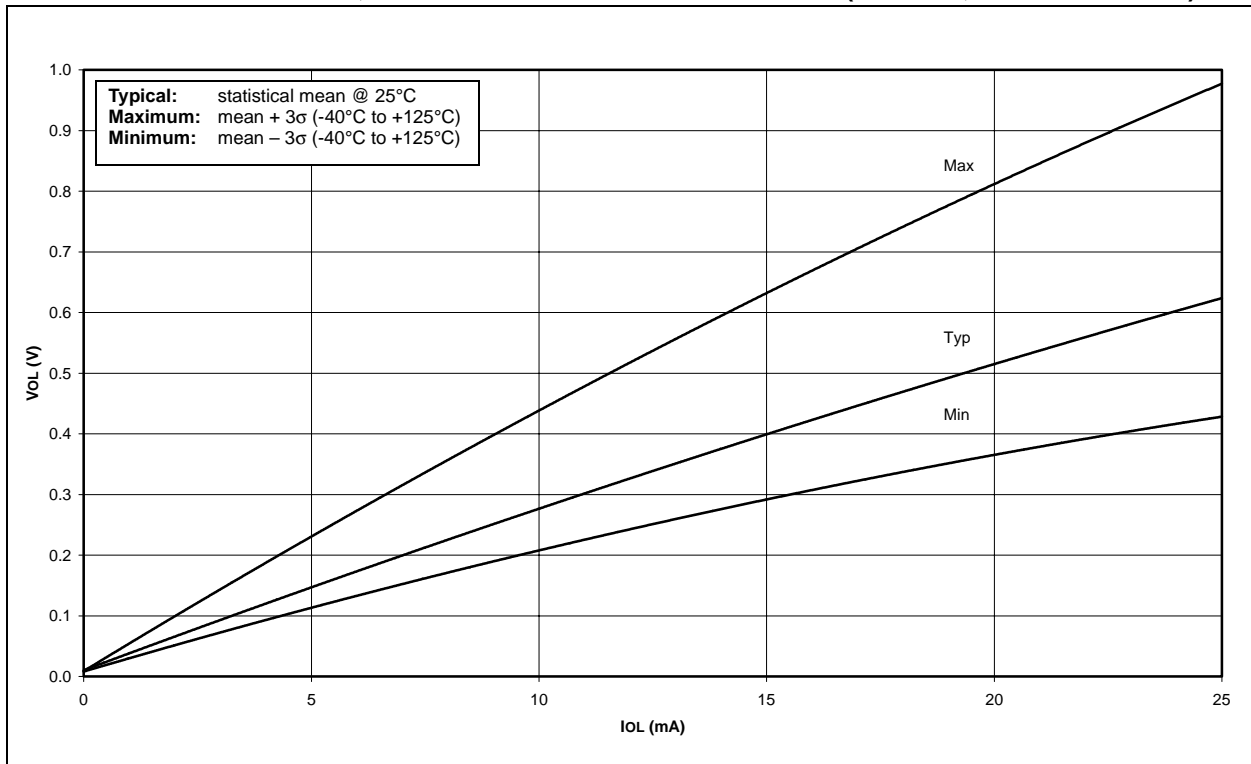
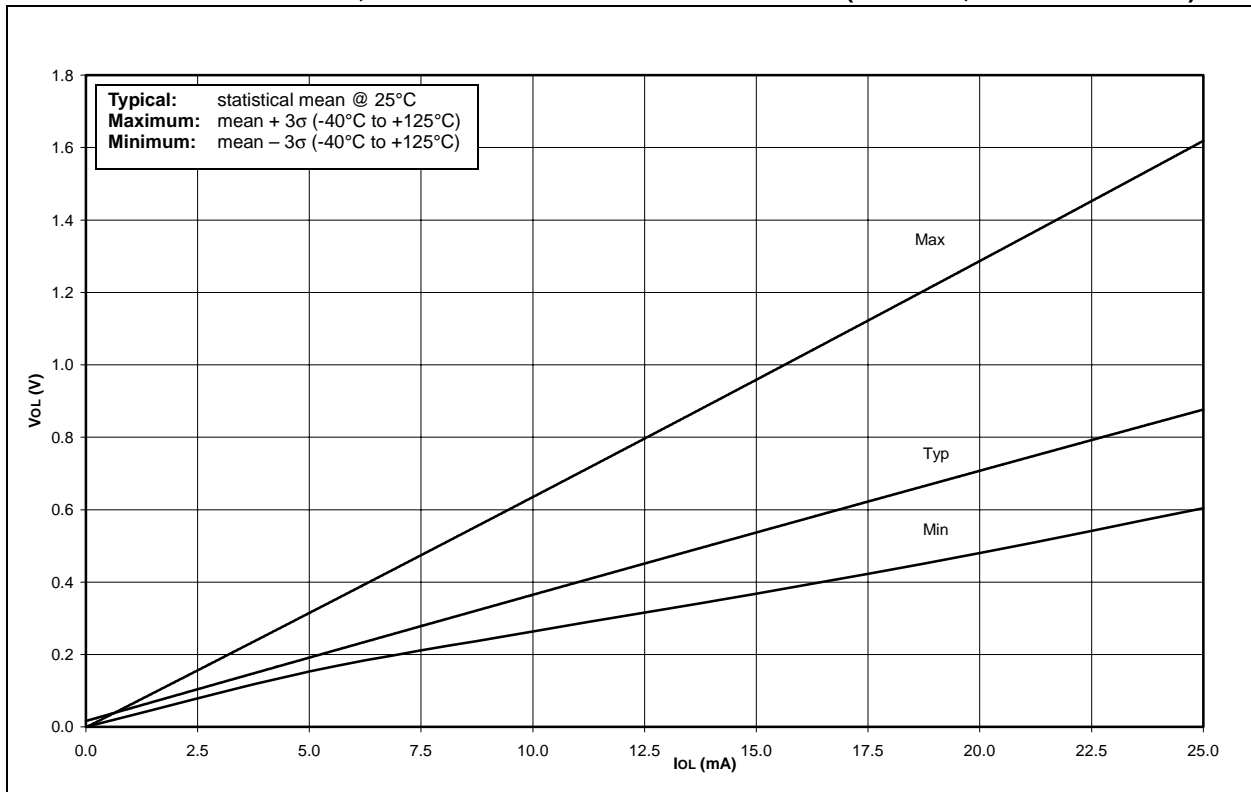

FIGURE 10-16: TYPICAL, MINIMUM AND MAXIMUM V_{OL} vs. I_{OL} ($V_{DD} = 3V$, $-40^{\circ}C$ TO $+125^{\circ}C$)



PIC16F84A

FIGURE 10-17: MINIMUM AND MAXIMUM V_{IN} vs. V_{DD} , (TTL INPUT, -40°C TO $+125^{\circ}\text{C}$)

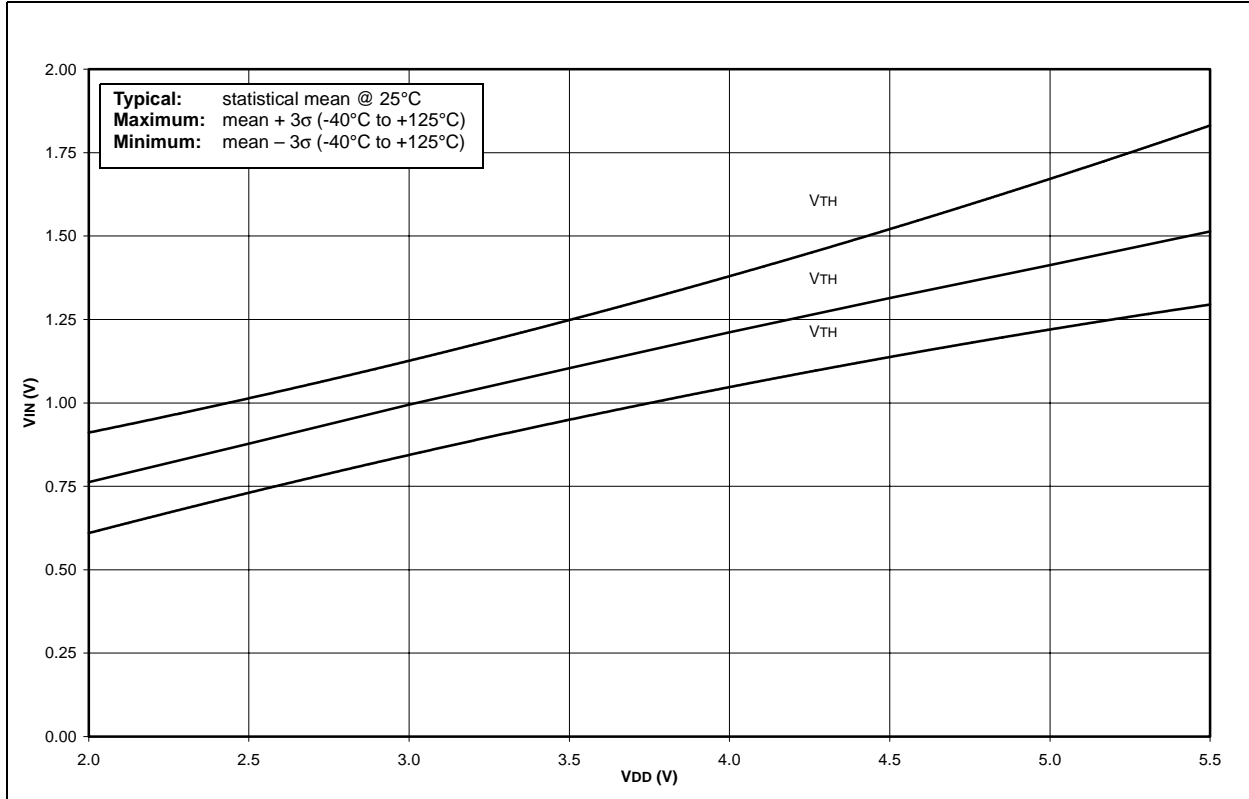
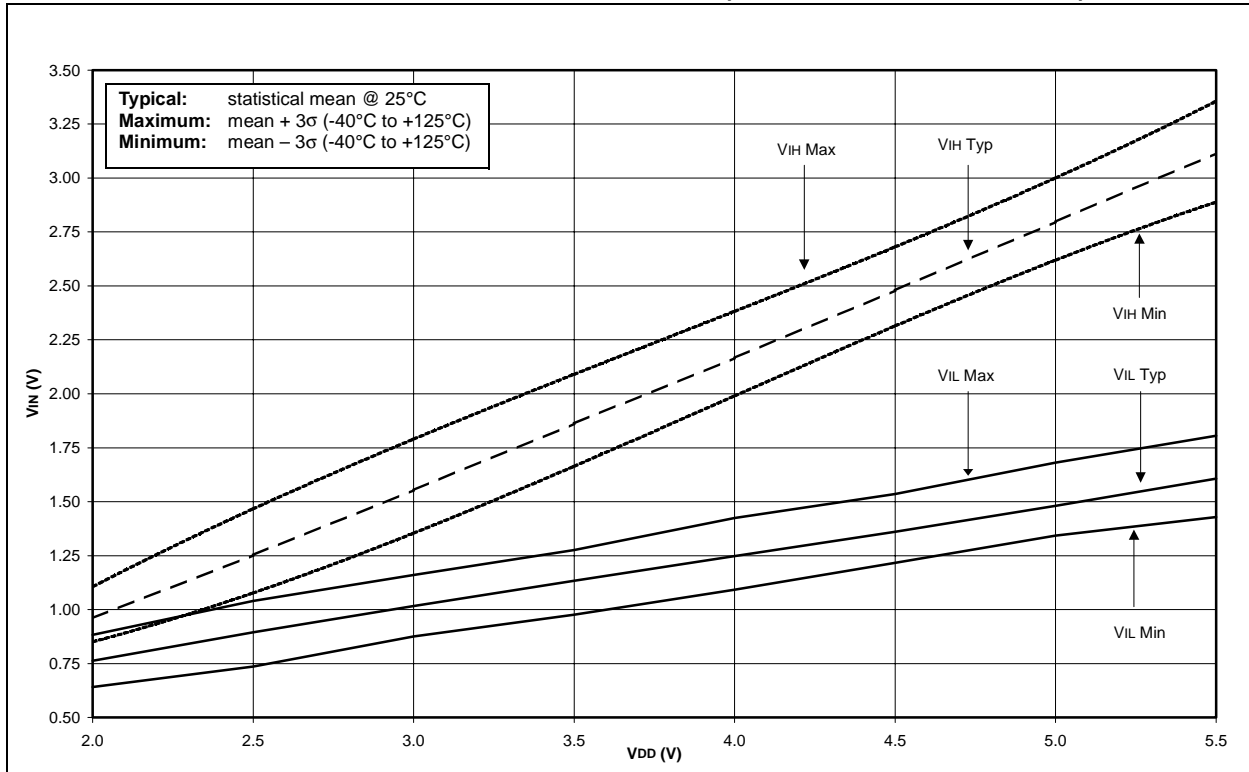

FIGURE 10-18: MINIMUM AND MAXIMUM V_{IN} vs. V_{DD} (ST INPUT, -40°C TO $+125^{\circ}\text{C}$)



11.0 PACKAGING INFORMATION

11.1 Package Marking Information

18-Lead PDIP

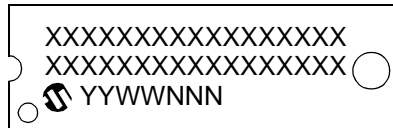

Example

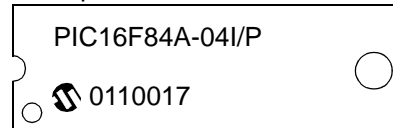

18-Lead SOIC

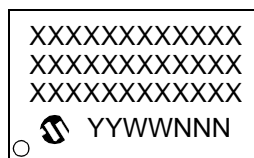

Example



20-Lead SSOP

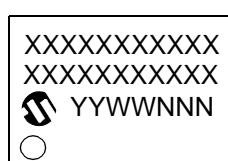

Example

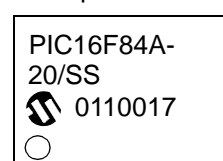

Legend:	XX...X	Customer specific information*
	Y	Year code (last digit of calendar year)
	YY	Year code (last 2 digits of calendar year)
	WW	Week code (week of January 1 is week '01')
	NNN	Alphanumeric traceability code

Note: In the event the full Microchip part number cannot be marked on one line, it will be carried over to the next line thus limiting the number of available characters for customer specific information.

* Standard PICmicro device marking consists of Microchip part number, year code, week code, and traceability code. For PICmicro device marking beyond this, certain price adders apply. Please check with your Microchip sales office. For QTP devices, any special marking adders are included in QTP price.

PIC16F84A

18-Lead Plastic Dual In-line (P) – 300 mil (PDIP)

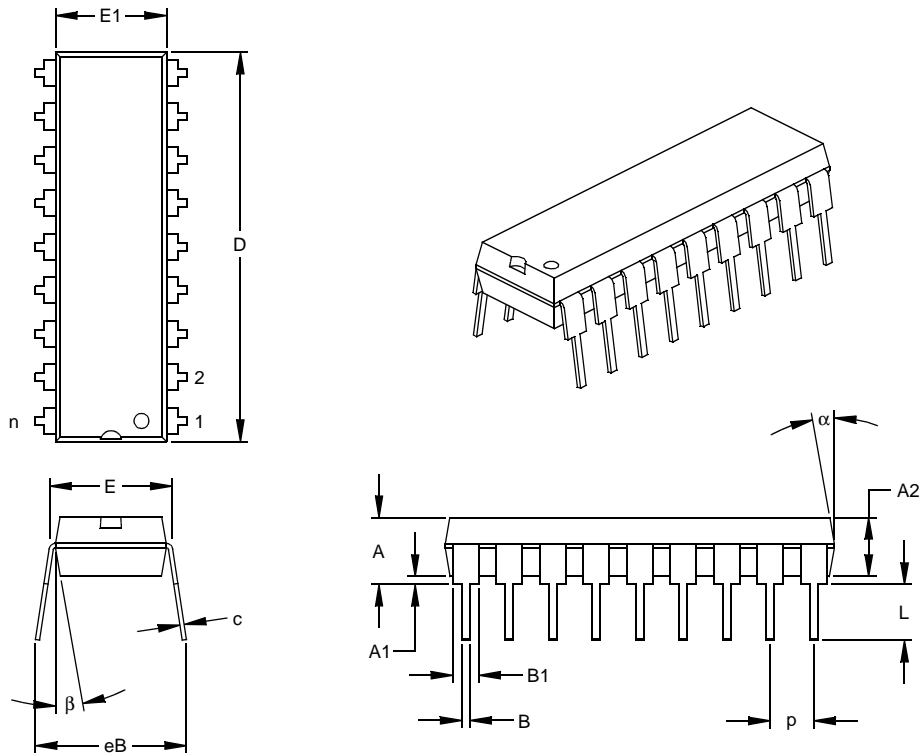

Dimension Limits	Units	INCHES*			MILLIMETERS		
		MIN	NOM	MAX	MIN	NOM	MAX
Number of Pins	n		18			18	
Pitch	p		.100			2.54	
Top to Seating Plane	A	.140	.155	.170	3.56	3.94	4.32
Molded Package Thickness	A2	.115	.130	.145	2.92	3.30	3.68
Base to Seating Plane	A1	.015			0.38		
Shoulder to Shoulder Width	E	.300	.313	.325	7.62	7.94	8.26
Molded Package Width	E1	.240	.250	.260	6.10	6.35	6.60
Overall Length	D	.890	.898	.905	22.61	22.80	22.99
Tip to Seating Plane	L	.125	.130	.135	3.18	3.30	3.43
Lead Thickness	c	.008	.012	.015	0.20	0.29	0.38
Upper Lead Width	B1	.045	.058	.070	1.14	1.46	1.78
Lower Lead Width	B	.014	.018	.022	0.36	0.46	0.56
Overall Row Spacing §	eB	.310	.370	.430	7.87	9.40	10.92
Mold Draft Angle Top	α	5	10	15	5	10	15
Mold Draft Angle Bottom	β	5	10	15	5	10	15

* Controlling Parameter
 § Significant Characteristic

Notes:

Dimensions D and E1 do not include mold flash or protrusions. Mold flash or protrusions shall not exceed .010" (0.254mm) per side.

JEDEC Equivalent: MS-001

Drawing No. C04-007

18-Lead Plastic Small Outline (SO) – Wide, 300 mil (SOIC)

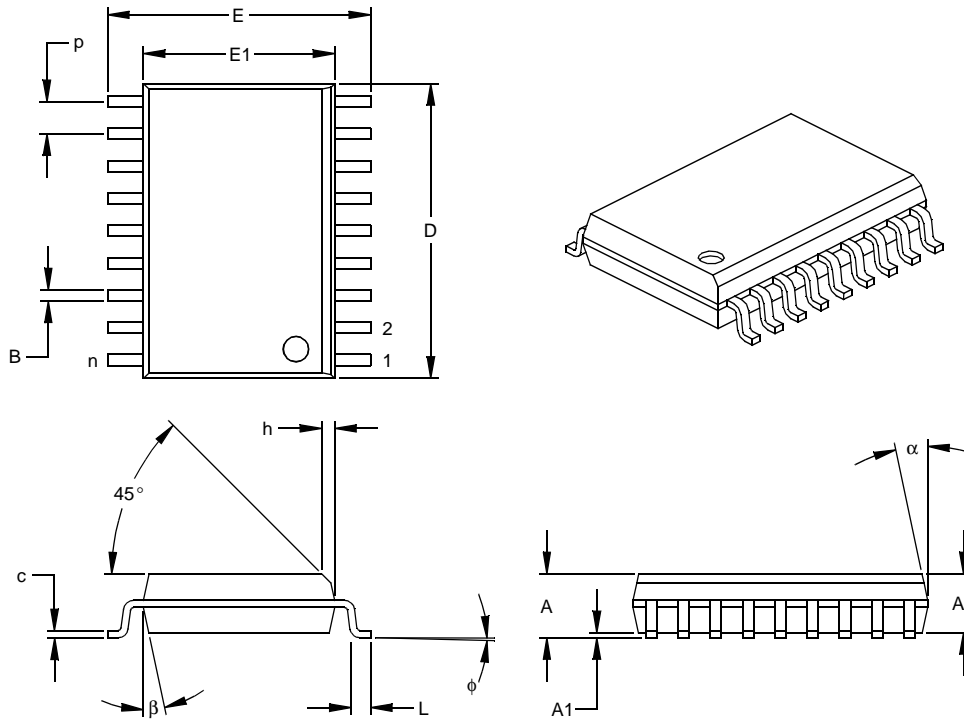

Dimension Limits	Units	INCHES*			MILLIMETERS		
		MIN	NOM	MAX	MIN	NOM	MAX
Number of Pins	n		18			18	
Pitch	p		.050			1.27	
Overall Height	A	.093	.099	.104	2.36	2.50	2.64
Molded Package Thickness	A2	.088	.091	.094	2.24	2.31	2.39
Standoff §	A1	.004	.008	.012	0.10	0.20	0.30
Overall Width	E	.394	.407	.420	10.01	10.34	10.67
Molded Package Width	E1	.291	.295	.299	7.39	7.49	7.59
Overall Length	D	.446	.454	.462	11.33	11.53	11.73
Chamfer Distance	h	.010	.020	.029	0.25	0.50	0.74
Foot Length	L	.016	.033	.050	0.41	0.84	1.27
Foot Angle	φ	0	4	8	0	4	8
Lead Thickness	c	.009	.011	.012	0.23	0.27	0.30
Lead Width	B	.014	.017	.020	0.36	0.42	0.51
Mold Draft Angle Top	α	0	12	15	0	12	15
Mold Draft Angle Bottom	β	0	12	15	0	12	15

* Controlling Parameter
 § Significant Characteristic

Notes:

Dimensions D and E1 do not include mold flash or protrusions. Mold flash or protrusions shall not exceed .010" (0.254mm) per side.

JEDEC Equivalent: MS-013

Drawing No. C04-051

PIC16F84A

20-Lead Plastic Shrink Small Outline (SS) – 209 mil, 5.30 mm (SSOP)

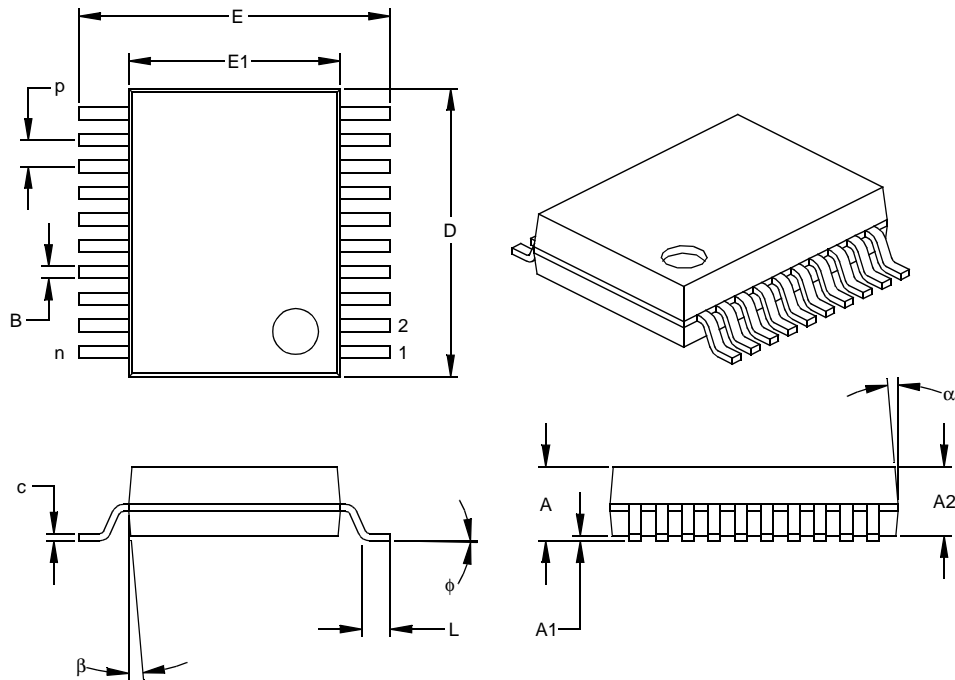

Units		INCHES*			MILLIMETERS		
Dimension Limits		MIN	NOM	MAX	MIN	NOM	MAX
Number of Pins	n		20			20	
Pitch	p		.026			0.65	
Overall Height	A	.068	.073	.078	1.73	1.85	1.98
Molded Package Thickness	A2	.064	.068	.072	1.63	1.73	1.83
Standoff §	A1	.002	.006	.010	0.05	0.15	0.25
Overall Width	E	.299	.309	.322	7.59	7.85	8.18
Molded Package Width	E1	.201	.207	.212	5.11	5.25	5.38
Overall Length	D	.278	.284	.289	7.06	7.20	7.34
Foot Length	L	.022	.030	.037	0.56	0.75	0.94
Lead Thickness	c	.004	.007	.010	0.10	0.18	0.25
Foot Angle	φ	0	4	8	0.00	101.60	203.20
Lead Width	B	.010	.013	.015	0.25	0.32	0.38
Mold Draft Angle Top	α	0	5	10	0	5	10
Mold Draft Angle Bottom	β	0	5	10	0	5	10

* Controlling Parameter
 § Significant Characteristic

Notes:

Dimensions D and E1 do not include mold flash or protrusions. Mold flash or protrusions shall not exceed .010" (0.254mm) per side.

JEDEC Equivalent: MO-150

Drawing No. C04-072

APPENDIX A: REVISION HISTORY

Version	Date	Revision Description
A	9/98	This is a new data sheet. However, the devices described in this data sheet are the upgrades to the devices found in the <i>PIC16F8X Data Sheet</i> , DS30430.
B	8/01	Added DC and AC Characteristics Graphs and Tables to Section 10.

PIC16F84A

APPENDIX B: CONVERSION CONSIDERATIONS

Considerations for converting from one PIC16X8X device to another are listed in Table 1.

TABLE 1: CONVERSION CONSIDERATIONS - PIC16C84, PIC16F83/F84, PIC16CR83/CR84, PIC16F84A

Difference	PIC16C84	PIC16F83/F84	PIC16CR83/CR84	PIC16F84A
Program Memory Size	1K x 14	512 x 14 / 1K x 14	512 x 14 / 1K x 14	1K x 14
Data Memory Size	36 x 8	36 x 8 / 68 x 8	36 x 8 / 68 x 8	68 x 8
Voltage Range	2.0V - 6.0V (-40°C to +85°C)	2.0V - 6.0V (-40°C to +85°C)	2.0V - 6.0V (-40°C to +85°C)	2.0V - 5.5V (-40°C to +125°C)
Maximum Operating Frequency	10 MHz	10 MHz	10 MHz	20 MHz
Supply Current (IDD). See parameter # D014 in the electrical specs for more detail.	IDD (typ) = 60 µA IDD (max) = 400 µA (LP osc, FOSC = 32 kHz, VDD = 2.0V, WDT disabled)	IDD (typ) = 15 µA IDD (max) = 45 µA (LP osc, FOSC = 32 kHz, VDD = 2.0V, WDT disabled)	IDD (typ) = 15 µA IDD (max) = 45 µA (LP osc, FOSC = 32 kHz, VDD = 2.0V, WDT disabled)	IDD (typ) = 15 µA IDD (max) = 45 µA (LP osc, FOSC = 32 kHz, VDD = 2.0V, WDT disabled)
Power-down Current (IPD). See parameters # D020, D021, and D021A in the electrical specs for more detail.	IPD (typ) = 26 µA IPD (max) = 100 µA (VDD = 2.0V, WDT disabled, industrial)	IPD (typ) = 0.4 µA IPD (max) = 9 µA (VDD = 2.0V, WDT disabled, industrial)	IPD (typ) = 0.4 µA IPD (max) = 6 µA (VDD = 2.0V, WDT disabled, industrial)	IPD (typ) = 0.4 µA IPD (max) = 1 µA (VDD = 2.0V, WDT disabled, industrial)
Input Low Voltage (VIL). See parameters # D032 and D034 in the electrical specs for more detail.	VIL (max) = 0.2VDD (OSC1, RC mode)	VIL (max) = 0.1VDD (OSC1, RC mode)	VIL (max) = 0.1VDD (OSC1, RC mode)	VIL (max) = 0.1VDD (OSC1, RC mode)
Input High Voltage (VIH). See parameter # D040 in the electrical specs for more detail.	VIH (min) = 0.36VDD (I/O Ports with TTL, 4.5V ≤ VDD ≤ 5.5V)	VIH (min) = 2.4V (I/O Ports with TTL, 4.5V ≤ VDD ≤ 5.5V)	VIH (min) = 2.4V (I/O Ports with TTL, 4.5V ≤ VDD ≤ 5.5V)	VIH (min) = 2.4V (I/O Ports with TTL, 4.5V ≤ VDD ≤ 5.5V)
Data EEPROM Memory Erase/Write cycle time (TDEW). See parameter # D122 in the electrical specs for more detail.	TDEW (typ) = 10 ms TDEW (max) = 20 ms	TDEW (typ) = 10 ms TDEW (max) = 20 ms	TDEW (typ) = 10 ms TDEW (max) = 20 ms	TDEW (typ) = 4 ms TDEW (max) = 8 ms
Port Output Rise/Fall time (TioR, TioF). See parameters #20, 20A, 21, and 21A in the electrical specs for more detail.	TioR, TioF (max) = 25 ns (C84) TioR, TioF (max) = 60 ns (LC84)	TioR, TioF (max) = 35 ns (C84) TioR, TioF (max) = 70 ns (LC84)	TioR, TioF (max) = 35 ns (C84) TioR, TioF (max) = 70 ns (LC84)	TioR, TioF (max) = 35 ns (C84) TioR, TioF (max) = 70 ns (LC84)
MCLR on-chip filter. See parameter #30 in the electrical specs for more detail.	No	Yes	Yes	Yes
PORTA and crystal oscillator values less than 500 kHz	For crystal oscillator configurations operating below 500 kHz, the device may generate a spurious internal Q-clock when PORTA<0> switches state.	N/A	N/A	N/A
RB0/INT pin	TTL	TTL/ST* (*Schmitt Trigger)	TTL/ST* (*Schmitt Trigger)	TTL/ST* (*Schmitt Trigger)

TABLE 1: CONVERSION CONSIDERATIONS - PIC16C84, PIC16F83/F84, PIC16CR83/CR84, PIC16F84A (CONTINUED)

Difference	PIC16C84	PIC16F83/F84	PIC16CR83/CR84	PIC16F84A
EEADR<7:6> and IDD	It is recommended that the EEADR<7:6> bits be cleared. When either of these bits is set, the maximum IDD for the device is higher than when both are cleared.	N/A	N/A	N/A
The polarity of the PWRTE bit	PWRTE	$\overline{\text{PWRTE}}$	$\overline{\text{PWRTE}}$	$\overline{\text{PWRTE}}$
Recommended value of REXT for RC oscillator circuits	REXT = 3k Ω - 100k Ω	REXT = 5k Ω - 100k Ω	REXT = 5k Ω - 100k Ω	REXT = 3k Ω - 100k Ω
GIE bit unintentional enable	If an interrupt occurs while the Global Interrupt Enable (GIE) bit is being cleared, the GIE bit may unintentionally be re-enabled by the user's Interrupt Service Routine (the RETFIE instruction).	N/A	N/A	N/A
Packages	PDIP, SOIC	PDIP, SOIC	PDIP, SOIC	PDIP, SOIC, SSOP
Open Drain High Voltage (VOD)	14V	12V	12V	8.5V

PIC16F84A

APPENDIX C: MIGRATION FROM BASELINE TO MID-RANGE DEVICES

This section discusses how to migrate from a baseline device (i.e., PIC16C5X) to a mid-range device (i.e., PIC16CXXX).

The following is the list of feature improvements over the PIC16C5X microcontroller family:

1. Instruction word length is increased to 14-bits. This allows larger page sizes, both in program memory (2K now as opposed to 512K before) and the register file (128 bytes now versus 32 bytes before).
2. A PC latch register (PCLATH) is added to handle program memory paging. PA2, PA1 and PA0 bits are removed from the STATUS register and placed in the OPTION register.
3. Data memory paging is redefined slightly. The STATUS register is modified.
4. Four new instructions have been added: RETURN, RETFIE, ADDLW, and SUBLW. Two instructions, TRIS and OPTION, are being phased out, although they are kept for compatibility with PIC16C5X.
5. OPTION and TRIS registers are made addressable.
6. Interrupt capability is added. Interrupt vector is at 0004h.
7. Stack size is increased to eight-deep.
8. RESET vector is changed to 0000h.
9. RESET of all registers is revisited. Five different RESET (and wake-up) types are recognized. Registers are reset differently.
10. Wake-up from SLEEP through interrupt is added.
11. Two separate timers, the Oscillator Start-up Timer (OST) and Power-up Timer (PWRT), are included for more reliable power-up. These timers are invoked selectively to avoid unnecessary delays on power-up and wake-up.
12. PORTB has weak pull-ups and interrupt-on-change features.
13. T0CKI pin is also a port pin (RA4/T0CKI).
14. FSR is a full 8-bit register.
15. "In system programming" is made possible. The user can program PIC16CXX devices using only five pins: VDD, VSS, VPP, RB6 (clock) and RB7 (data in/out).

To convert code written for PIC16C5X to PIC16F84A, the user should take the following steps:

1. Remove any program memory page select operations (PA2, PA1, PA0 bits) for CALL, GOTO.
2. Revisit any computed jump operations (write to PC or add to PC, etc.) to make sure page bits are set properly under the new scheme.
3. Eliminate any data memory page switching. Redefine data variables for reallocation.
4. Verify all writes to STATUS, OPTION, and FSR registers since these have changed.
5. Change RESET vector to 0000h.

INDEX

A

Absolute Maximum Ratings	49
AC (Timing) Characteristics	55
Architecture, Block Diagram	3
Assembler	
MPASM Assembler	43

B

Banking, Data Memory	6
Block Diagrams	
Crystal/Ceramic Resonator Operation	22
External Clock Input Operation	22
External Power-on Reset Circuit	26
Interrupt Logic	29
On-Chip Reset	24
PIC16F84A	3
PORTA	
RA3:RA0 Pins	15
RA4 Pins	15
PORTB	
RB3:RB0 Pins	17
RB7:RB4 Pins	17
RC Oscillator Mode	23
Timer0	19
Timer0/WDT Prescaler	20
Watchdog Timer (WDT)	31

C

C (Carry) bit	8
CLKIN Pin	4
CLKOUT Pin	4
Code Examples	
Clearing RAM Using Indirect Addressing	11
Data EEPROM Write Verify	14
Indirect Addressing	11
Initializing PORTA	15
Initializing PORTB	17
Reading Data EEPROM	14
Saving STATUS and W Registers in RAM	30
Writing to Data EEPROM	14
Code Protection	21, 33
Configuration Bits	21
Configuration Word	21
Conversion Considerations	76

D

Data EEPROM Memory	13
Associated Registers	14
EEADR Register	7, 13, 25
EECON1 Register	7, 13, 25
EECON2 Register	7, 13, 25
EEDATA Register	7, 13, 25
Write Complete Enable (EEIE Bit)	29
Write Complete Flag (EEIF Bit)	29
Data EEPROM Write Complete	29
Data Memory	6
Bank Select (RP0 Bit)	6
Banking	6
DC Bit	8
DC Characteristics	51, 53
Development Support	43
Device Overview	3

E

EECON1 Register	
EEIF Bit	29
Electrical Characteristics	49
Load Conditions	56
Parameter Measurement Information	56
PIC16F84A-04 Voltage-Frequency Graph	50
PIC16F84A-20 Voltage-Frequency Graph	50
PIC16LF84A-04 Voltage-Frequency Graph	50
Temperature and Voltage Specifications - AC	56
Endurance	1
Errata	2
External Clock Input (RA4/T0CKI). <i>See</i> Timer0	
External Interrupt Input (RB0/INT). <i>See</i> Interrupt Sources	
External Power-on Reset Circuit	26

F

Firmware Instructions	35
-----------------------------	----

I

I/O Ports	15
ICEPIC In-Circuit Emulator	44
ID Locations	21, 33
In-Circuit Serial Programming (ICSP)	21, 33
INDF Register	7
Indirect Addressing	11
FSR Register	6, 7, 11, 25
INDF Register	7, 11, 25
Instruction Format	35
Instruction Set	35
ADDLW	37
ADDWF	37
ANDLW	37
ANDWF	37
BCF	37
BSF	37
BTFSF	38
BTFSS	37
CALL	38
CLRF	38
CLRWF	38
CLRWDW	38
COMF	38
DECF	38
DECFSZ	39
GOTO	39
INCF	39
INCFSZ	39
IORLW	39
IORWF	39
MOVF	40
MOVLW	40
MOVWF	40
NOP	40
RETFIE	40
RETLW	40
RETURN	40
RLF	41
RRF	41
SLEEP	41
SUBLW	41
SUBWF	41
SWAPF	41
XORLW	42

PIC16F84A

XORWF.....	42	T0CS Bit.....	9
Summary Table.....	36	T0SE Bit.....	9
INT Interrupt (RB0/INT).....	29	OPTION_REG Register.....	7, 18, 20, 25
INTCON Register.....	7, 10, 20, 25, 29	INTEDG Bit.....	29
EEIE Bit.....	29	PS2:PS0 Bits.....	19
GIE Bit.....	10, 29	PSA Bit.....	19
INTE Bit.....	10, 29	OSC1 Pin.....	4
INTF Bit.....	10, 29	OSC2 Pin.....	4
PEIE Bit.....	10	Oscillator Configuration.....	21, 22
RBIE Bit.....	10, 29	Block Diagram.....	22, 23
RBIF Bit.....	10, 17, 29	Capacitor Selection for Ceramic Resonators.....	22
T0IE Bit.....	10, 29	Capacitor Selection for Crystal Oscillator.....	23
T0IF Bit.....	10, 20, 29	Crystal Oscillator/Ceramic Resonators.....	22
Interrupt Sources.....	21, 29	HS.....	22, 28
Block Diagram.....	29	LP.....	22, 28
Data EEPROM Write Complete.....	29, 32	Oscillator Types.....	22
Interrupt-on-Change (RB7:RB4).....	4, 17, 29, 32	RC.....	22, 23, 28
RB0/INT Pin, External.....	4, 18, 29, 32	XT.....	22, 28
TMR0 Overflow.....	20, 29		
Interrupts, Context Saving During.....	30	P	
Interrupts, Enable Bits		Packaging Information.....	71
Data EEPROM Write Complete Enable		Marking.....	71
(EEIE Bit).....	29	PD Bit.....	8
Global Interrupt Enable (GIE Bit).....	10	PICDEM 1 Low Cost PICmicro	
Interrupt-on-Change (RB7:RB4) Enable		Demonstration Board.....	45
(RBIE Bit).....	10	PICDEM 17 Demonstration Board.....	46
Peripheral Interrupt Enable (PEIE Bit).....	10	PICDEM 2 Low Cost PIC16CXX	
RB0/INT Enable (INTE Bit).....	10	Demonstration Board.....	45
TMR0 Overflow Enable (T0IE Bit).....	10	PICDEM 3 Low Cost PIC16CXXX	
Interrupts, Flag Bits.....	29	Demonstration Board.....	46
Data EEPROM Write Complete Flag		PICSTART Plus Entry Level Development	
(EEIF Bit).....	29	Programmer.....	45
Interrupt-on-Change (RB7:RB4) Flag		Pinout Descriptions.....	4
(RBIF Bit).....	10	Pointer, FSR.....	11
RB0/INT Flag (INTF Bit).....	10	POR. See Power-on Reset	
TMR0 Overflow Flag (T0IF Bit).....	10	PORTA.....	4, 15
IRP bit.....	8	Associated Registers.....	16
		Functions.....	16
K		Initializing.....	15
KEELOQ Evaluation and Programming Tools.....	46	PORTA Register.....	7, 15, 16, 25
		RA3:RA0 Block Diagram.....	15
M		RA4 Block Diagram.....	15
Master Clear (<u>MCLR</u>)		RA4/T0CKI Pin.....	4, 15, 19
<u>MCLR</u> Pin.....	4	TRISA Register.....	7, 15, 16, 20, 25
<u>MCLR</u> Reset, Normal Operation.....	24	PORTB.....	4, 17
<u>MCLR</u> Reset, SLEEP.....	24, 32	Associated Registers.....	18
Memory Organization.....	5	Functions.....	18
Data EEPROM Memory.....	13	Initializing.....	17
Data Memory.....	6	PORTB Register.....	7, 17, 18, 25
Program Memory.....	5	Pull-up Enable Bit (RBPU Bit).....	9
Migration from Baseline to Mid-Range Devices.....	78	RB0/INT Edge Select (INTEDG Bit).....	9
MPLAB C17 and MPLAB C18 C Compilers.....	43	RB0/INT Pin, External.....	4, 18, 29
MPLAB ICD In-Circuit Debugger.....	45	RB3:RB0 Block Diagram.....	17
MPLAB ICE High Performance Universal In-Circuit		RB7:RB4 Block Diagram.....	17
Emulator with MPLAB IDE.....	44	RB7:RB4 Interrupt-on-Change.....	4, 17, 29
MPLAB Integrated Development Environment		RB7:RB4 Interrupt-on-Change	
Software.....	43	Enable (RBIE Bit).....	10
MPLINK Object Linker/MPLIB Object Librarian.....	44	RB7:RB4 Interrupt-on-Change	
		Flag (RBIF Bit).....	10, 17
O		TRISB Register.....	7, 17, 18, 25
OPCODE Field Descriptions.....	35	Postscaler, WDT	
OPTION Register.....	9	Assignment (PSA Bit).....	9
INTEDG Bit.....	9	Rate Select (PS2:PS0 Bits).....	9
PS2:PS0 Bits.....	9	Postscaler. See Prescaler	
PSA Bit.....	9	Power-down (PD) Bit. See Power-on Reset (POR)	
RBPU Bit.....	9	Power-down Mode. See SLEEP	

Power-on Reset (POR)	21, 24, 26
Oscillator Start-up Timer (OST)	21, 26
PD Bit	8, 24, 28, 32, 33
Power-up Timer (PWRT)	21, 26
Time-out Sequence	28
Time-out Sequence on Power-up	27, 28
TO Bit	8, 24, 28, 30, 32, 33
Prescaler	19
Assignment (PSA Bit)	19
Block Diagram	20
Rate Select (PS2:PS0 Bits)	19
Switching Prescaler Assignment	20
Prescaler, Timer0	
Assignment (PSA Bit)	9
Rate Select (PS2:PS0 Bits)	9
PRO MATE II Universal Device Programmer	45
Program Counter	11
PCL Register	7, 11, 25
PCLATH Register	7, 11, 25
Reset Conditions	24
Program Memory	5
General Purpose Registers	6
Interrupt Vector	5, 29
RESET Vector	5
Special Function Registers	6, 7
Programming, Device Instructions	35
R	
RAM. <i>See</i> Data Memory	
Register File	6
Register File Map	6
Registers	
Configuration Word	21
EECON1 (EEPROM Control)	13
INTCON	10
OPTION	9
STATUS	8
Reset	21, 24
Block Diagram	24, 26
MCLR Reset. <i>See</i> MCLR	
Power-on Reset (POR). <i>See</i> Power-on Reset (POR)	
Reset Conditions for All Registers	25
Reset Conditions for Program Counter	24
Reset Conditions for STATUS Register	24
WDT Reset. <i>See</i> Watchdog Timer (WDT)	
Revision History	75
RP1:RP0 (Bank Select) bits	8
S	
Saving W Register and STATUS in RAM	30
SLEEP	21, 24, 29, 32
Software Simulator (MPLAB SIM)	44
Special Features of the CPU	21
Special Function Registers	6, 7
Speed, Operating	1, 22, 23, 57
Stack	11
STATUS Register	7, 8, 25, 30
C Bit	8
DC Bit. <i>See</i> MCLR	
PD Bit	8, 24, 28, 32, 33
RESET Conditions	24
RP0 Bit	6
TO Bit	8, 24, 28, 30, 32, 33
Z Bit	8

T

Time-out (TO) Bit. <i>See</i> Power-on Reset (POR)	
Timer0	19
Associated Registers	20
Block Diagram	19
Clock Source Edge Select (T0SE Bit)	9
Clock Source Select (T0CS Bit)	9
Overflow Enable (T0IE Bit)	10, 29
Overflow Flag (T0IF Bit)	10, 20, 29
Overflow Interrupt	20, 29
Prescaler. <i>See</i> Prescaler	
RA4/T0CKI Pin, External Clock	19
TMR0 Register	7, 20, 25
Timing Conditions	56
Timing Diagrams	
CLKOUT and I/O	58
Diagrams and Specifications	57
CLKOUT and I/O Requirements	58
External Clock Requirements	57
RESET, Watchdog Timer, Oscillator Start-up Timer and Power-up Timer Requirements	59
Timer0 Clock Requirements	60
External Clock	57
RESET, Watchdog Timer, Oscillator Start-up Timer and Power-up Timer	59
Time-out Sequence on Power-up	27, 28
Timer0 Clock	60
Wake-up From SLEEP Through Interrupt	32
Timing Parameter Symbology	55
TO bit	8

W

W Register	25, 30
Wake-up from SLEEP	21, 26, 28, 29, 32
Interrupts	32, 33
MCLR Reset	32
WDT Reset	32
Watchdog Timer (WDT)	21, 30
Block Diagram	31
Postscaler. <i>See</i> Prescaler	
Programming Considerations	31
RC Oscillator	30
Time-out Period	30
WDT Reset, Normal Operation	24
WDT Reset, SLEEP	24, 32
WWW, On-Line Support	2

Z

Z (Zero) bit	8
--------------------	---

PIC16F84A

NOTES:

ON-LINE SUPPORT

Microchip provides on-line support on the Microchip World Wide Web (WWW) site.

The web site is used by Microchip as a means to make files and information easily available to customers. To view the site, the user must have access to the Internet and a web browser, such as Netscape® or Microsoft® Explorer. Files are also available for FTP download from our FTP site.

Connecting to the Microchip Internet Web Site

The Microchip web site is available by using your favorite Internet browser to attach to:

www.microchip.com

The file transfer site is available by using an FTP service to connect to:

<ftp://ftp.microchip.com>

The web site and file transfer site provide a variety of services. Users may download files for the latest Development Tools, Data Sheets, Application Notes, User's Guides, Articles and Sample Programs. A variety of Microchip specific business information is also available, including listings of Microchip sales offices, distributors and factory representatives. Other data available for consideration is:

- Latest Microchip Press Releases
- Technical Support Section with Frequently Asked Questions
- Design Tips
- Device Errata
- Job Postings
- Microchip Consultant Program Member Listing
- Links to other useful web sites related to Microchip Products
- Conferences for products, Development Systems, technical information and more
- Listing of seminars and events

Systems Information and Upgrade Hot Line

The Systems Information and Upgrade Line provides system users a listing of the latest versions of all of Microchip's development systems software products. Plus, this line provides information on how customers can receive any currently available upgrade kits. The Hot Line Numbers are:

1-800-755-2345 for U.S. and most of Canada, and

1-480-792-7302 for the rest of the world.

013001

PIC16F84A

READER RESPONSE

It is our intention to provide you with the best documentation possible to ensure successful use of your Microchip product. If you wish to provide your comments on organization, clarity, subject matter, and ways in which our documentation can better serve you, please FAX your comments to the Technical Publications Manager at (480) 792-4150.

Please list the following information, and use this outline to provide us with your comments about this Data Sheet.

To: Technical Publications Manager Total Pages Sent
RE: Reader Response
From: Name _____
Company _____
Address _____
City / State / ZIP / Country _____
Telephone: (____) _____ - _____ FAX: (____) _____ - _____

Application (optional):

Would you like a reply? ___Y ___N

Device: PIC16F84A Literature Number: DS35007B

Questions:

1. What are the best features of this document?

2. How does this document meet your hardware and software development needs?

3. Do you find the organization of this data sheet easy to follow? If not, why?

4. What additions to the data sheet do you think would enhance the structure and subject?

5. What deletions from the data sheet could be made without affecting the overall usefulness?

6. Is there any incorrect or misleading information (what and where)?

7. How would you improve this document?

8. How would you improve our software, systems, and silicon products?

PIC16F84A PRODUCT IDENTIFICATION SYSTEM

To order or obtain information (e.g., on pricing or delivery) refer to the factory or the listed sales office.

<u>PART NO.</u>	<u>-XX</u>	<u>X</u>	<u>/XX</u>	<u>XXX</u>	
Device	Frequency Range	Temperature Range	Package	Pattern	
Device	PIC16F84A ⁽¹⁾ , PIC16F84AT ⁽²⁾ PIC16LF84A ⁽¹⁾ , PIC16LF84AT ⁽²⁾				Examples: a) PIC16F84A -04/P 301 = Commercial temp., PDIP package, 4 MHz, normal VDD limits, QTP pattern #301. b) PIC16LF84A - 04I/SO = Industrial temp., SOIC package, 200 kHz, Extended VDD limits. c) PIC16F84A - 20I/P = Industrial temp., PDIP package, 20 MHz, normal VDD limits. Note 1: F = Standard VDD range LF = Extended VDD range Note 2: T = in tape and reel - SOIC and SSOP packages only.
Frequency Range	04 = 4 MHz 20 = 20 MHz				
Temperature Range	- = 0°C to +70°C I = -40°C to +85°C				
Package	P = PDIP SO = SOIC (Gull Wing, 300 mil body) SS = SSOP				
Pattern	QTP, SQTP, ROM Code (factory specified) or Special Requirements. Blank for OTP and Windowed devices.				

Sales and Support

Data Sheets

Products supported by a preliminary Data Sheet may have an errata sheet describing minor operational differences and recommended workarounds. To determine if an errata sheet exists for a particular device, please contact one of the following:

1. Your local Microchip sales office
2. The Microchip Corporate Literature Center U.S. FAX: (480) 792-7277
3. The Microchip Worldwide Site (www.microchip.com)

Please specify which device, revision of silicon and Data Sheet (include Literature #) you are using.

New Customer Notification System

Register on our web site (www.microchip.com/cn) to receive the most current information on our products.



WORLDWIDE SALES AND SERVICE

AMERICAS

Corporate Office

2355 West Chandler Blvd.
Chandler, AZ 85224-6199
Tel: 480-792-7200 Fax: 480-792-7277
Technical Support: 480-792-7627
Web Address: <http://www.microchip.com>

Rocky Mountain

2355 West Chandler Blvd.
Chandler, AZ 85224-6199
Tel: 480-792-7966 Fax: 480-792-7456

Atlanta

500 Sugar Mill Road, Suite 200B
Atlanta, GA 30350
Tel: 770-640-0034 Fax: 770-640-0307

Austin - Analog

13740 North Highway 183
Building J, Suite 4
Austin, TX 78750
Tel: 512-257-3370 Fax: 512-257-8526

Boston

2 Lan Drive, Suite 120
Westford, MA 01886
Tel: 978-692-3848 Fax: 978-692-3821

Boston - Analog

Unit A-8-1 Millbrook Tarry Condominium
97 Lowell Road
Concord, MA 01742
Tel: 978-371-6400 Fax: 978-371-0050

Chicago

333 Pierce Road, Suite 180
Itasca, IL 60143
Tel: 630-285-0071 Fax: 630-285-0075

Dallas

4570 Westgrove Drive, Suite 160
Addison, TX 75001
Tel: 972-818-7423 Fax: 972-818-2924

Dayton

Two Prestige Place, Suite 130
Miamisburg, OH 45342
Tel: 937-291-1654 Fax: 937-291-9175

Detroit

Tri-Atria Office Building
32255 Northwestern Highway, Suite 190
Farmington Hills, MI 48334
Tel: 248-538-2250 Fax: 248-538-2260

Los Angeles

18201 Von Karman, Suite 1090
Irvine, CA 92612
Tel: 949-263-1888 Fax: 949-263-1338

New York

150 Motor Parkway, Suite 202
Hauppauge, NY 11788
Tel: 631-273-5305 Fax: 631-273-5335

San Jose

Microchip Technology Inc.
2107 North First Street, Suite 590
San Jose, CA 95131
Tel: 408-436-7950 Fax: 408-436-7955

Toronto

6285 Northam Drive, Suite 108
Mississauga, Ontario L4V 1X5, Canada
Tel: 905-673-0699 Fax: 905-673-6509

ASIA/PACIFIC

Australia

Microchip Technology Australia Pty Ltd
Suite 22, 41 Rawson Street
Epping 2121, NSW
Australia
Tel: 61-2-9868-6733 Fax: 61-2-9868-6755

China - Beijing

Microchip Technology Consulting (Shanghai)
Co., Ltd., Beijing Liaison Office
Unit 915
Bei Hai Wan Tai Bldg.
No. 6 Chaoyangmen Beidajie
Beijing, 100027, No. China
Tel: 86-10-85282100 Fax: 86-10-85282104

China - Chengdu

Microchip Technology Consulting (Shanghai)
Co., Ltd., Chengdu Liaison Office
Rm. 2401, 24th Floor,
Ming Xing Financial Tower
No. 88 TIDU Street
Chengdu 610016, China
Tel: 86-28-6766200 Fax: 86-28-6766599

China - Fuzhou

Microchip Technology Consulting (Shanghai)
Co., Ltd., Fuzhou Liaison Office
Rm. 531, North Building
Fujian Foreign Trade Center Hotel
73 Wusi Road
Fuzhou 350001, China
Tel: 86-591-7557563 Fax: 86-591-7557572

China - Shanghai

Microchip Technology Consulting (Shanghai)
Co., Ltd.
Room 701, Bldg. B
Far East International Plaza
No. 317 Xian Xia Road
Shanghai, 200051
Tel: 86-21-6275-5700 Fax: 86-21-6275-5060

China - Shenzhen

Microchip Technology Consulting (Shanghai)
Co., Ltd., Shenzhen Liaison Office
Rm. 1315, 13/F, Shenzhen Kerry Centre,
Renminnan Lu
Shenzhen 518001, China
Tel: 86-755-2350361 Fax: 86-755-2366086

Hong Kong

Microchip Technology Hongkong Ltd.
Unit 901-6, Tower 2, Metrol plaza
223 Hing Fong Road
Kwai Fong, N.T., Hong Kong
Tel: 852-2401-1200 Fax: 852-2401-3431

India

Microchip Technology Inc.
India Liaison Office
Divyasree Chambers
1 Floor, Wing A (A3/A4)
No. 11, O'Shaughnessey Road
Bangalore, 560 025, India
Tel: 91-80-2290061 Fax: 91-80-2290062

Japan

Microchip Technology Japan K.K.
Benex S-1 6F
3-18-20, Shinyokohama
Kohoku-Ku, Yokohama-shi
Kanagawa, 222-0033, Japan
Tel: 81-45-471-6166 Fax: 81-45-471-6122

Korea

Microchip Technology Korea
168-1, Youngbo Bldg. 3 Floor
Samsung-Dong, Kangnam-Ku
Seoul, Korea 135-882
Tel: 82-2-554-7200 Fax: 82-2-558-5934

Singapore

Microchip Technology Singapore Pte Ltd.
200 Middle Road
#07-02 Prime Centre
Singapore, 188980
Tel: 65-334-8870 Fax: 65-334-8850

Taiwan

Microchip Technology Taiwan
11F-3, No. 207
Tung Hua North Road
Taipei, 105, Taiwan
Tel: 886-2-2717-7175 Fax: 886-2-2545-0139

EUROPE

Denmark

Microchip Technology Denmark ApS
Regus Business Centre
Lautrup høj 1-3
Ballerup DK-2750 Denmark
Tel: 45 4420 9895 Fax: 45 4420 9910

France

Arizona Microchip Technology SARL
Parc d'Activite du Moulin de Massy
43 Rue du Saule Trapu
Batiment A - 1er Etage
91300 Massy, France
Tel: 33-1-69-53-63-20 Fax: 33-1-69-30-90-79

Germany

Arizona Microchip Technology GmbH
Gustav-Heinemann Ring 125
D-81739 Munich, Germany
Tel: 49-89-627-144 0 Fax: 49-89-627-144-44

Germany - Analog

Lochamer Strasse 13
D-82152 Martinsried, Germany
Tel: 49-89-895650-0 Fax: 49-89-895650-22

Italy

Arizona Microchip Technology SRL
Centro Direzionale Colleoni
Palazzo Taurus 1 V. Le Colleoni 1
20041 Agrate Brianza
Milan, Italy
Tel: 39-039-65791-1 Fax: 39-039-6899883

United Kingdom

Arizona Microchip Technology Ltd.
505 Eskdale Road
Winnersh Triangle
Wokingham
Berkshire, England RG41 5TU
Tel: 44 118 921 5869 Fax: 44-118 921-5820

08/01/01